

Euclidean Geometry

Preliminary Version

Paul Yiu

Department of Mathematics
Florida Atlantic University

Fall 1998

Table of Contents

1	Pythagoras Theorem and its applications	
1.1.	Pythagoras Theorem and its Converse	1
1.2.	Euclid's proof of Pythagoras Theorem	5
1.3.	Construction of regular polygons	8
1.4.	The regular pentagon	10
1.5.	The cosine formula and its applications	12
1.6.	Synthetic proofs of Steiner - Lehmus Theorem	16
2	The circumcircle and the incircle	
2.1.	The circumcircle	18
2.2.	The incircle	21
2.3.	The excircles	27
2.4.	Heron's formula for the area of a triangle	30
3	The Euler line and the nine-point circle	
3.1.	The orthocenter	34
3.2.	The Euler line	36
3.3.	The nine-point circle	38
3.4.	The power of a point with respect to a circle	40
3.5.	Distance between O and I	43
4	Circles	
4.1.	Tests for concyclic points	45
4.2.	Tangents to circles	46
4.3.	Tangent circles	50
4.4.	Mixtilinear incircles	56
4.5.	Mixtilinear excircles	60

5	The Shoemaker's knife	
5.1.	The shoemaker's knife	61
5.2.	Archimedean circles in the shoemaker's knife	66
5.3.	The Schoch line	69
6	The use of complex numbers	
6.1.	Review on complex numbers	73
6.2.	Coordinatization	74
6.3.	Feuerbach Theorem	75
6.4.	The shape of a triangle	78
6.5.	Concyclic points	82
6.6.	Construction of the regular 17-gon	83
7	The Menelaus and Ceva Theorems	
7.1.	Harmonic conjugates	87
7.2.	Appolonius circles	89
7.3.	Menelaus Theorem	91
7.4.	Ceva Theorem	93
7.5.	Examples	94
7.6.	Trigonometric version of Ceva Theorem	96
7.7.	Mixtilinear incircles	98
7.8.	Duality	100
7.9.	Triangles in perspective	101

8 Homogeneous coordinates

- 8.1. Coordinates of points on a line 104
- 8.2. Coordinates with respect to a triangle 104
- 8.3. The centers of similitude of two circles 108
- 8.4. Mixtilinear incircles 98
- 8.5. Isotomic conjugates 112
- 8.6. Isogonal conjugates 114
- 8.7. Point with equal parallel intercepts 121

9 Chains of circles

- 9.1. Congruent - incircle problem 127
- 9.2. A construction problem 135
- 9.3. Circles with a common point 136
- 9.4. Malfatti circles 139
- 9.5. Chains of circles tangent to a given circle 141

10 Quadrilaterals

- 10.1. Area formula 146
- 10.2. Ptolemy's Theorem 148
- 10.3. Circumscribable quadrilaterals 156
- 10.4. Orthodiagonal quadrilaterals 158
- 10.5. Bicentric quadrilaterals 159

Chapter 1

Pythagoras Theorem and Its Applications

1.1 Pythagoras Theorem and its converse

1.1.1 Pythagoras Theorem

The lengths $a \leq b < c$ of the sides of a right triangle satisfy the relation

$$a^2 + b^2 = c^2.$$

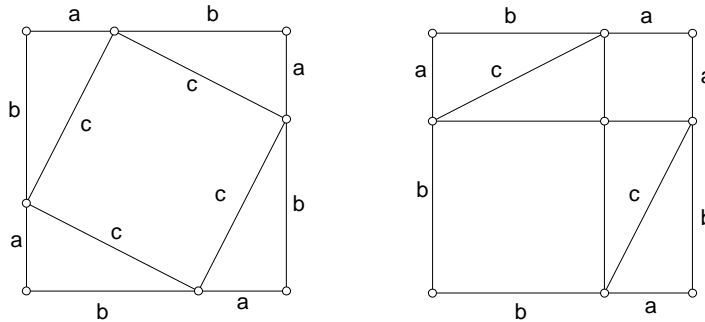

1.1.2 Converse Theorem

If the lengths of the sides of a triangles satisfy the relation $a^2 + b^2 = c^2$, then the triangle contains a right angle.

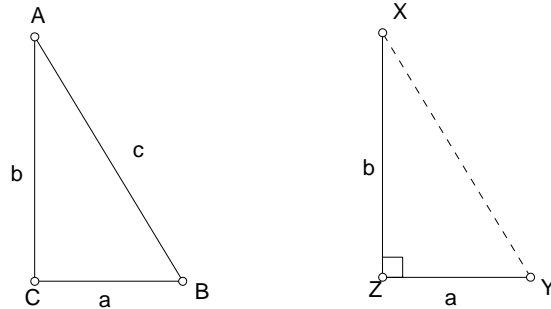

Proof. Let ABC be a triangle with $BC = a$, $CA = b$, and $AB = c$ satisfying $a^2 + b^2 = c^2$. Consider another triangle XYZ with

$$YZ = a, \quad XZ = b, \quad \angle XZY = 90^\circ.$$

By the Pythagorean theorem, $XY^2 = a^2 + b^2 = c^2$, so that $XY = c$. Thus the triangles $\triangle ABC \cong \triangle XYZ$ by the SSS test. This means that $\angle ACB = \angle XZY$ is a right angle.

Exercise

- Dissect two given squares into triangles and quadrilaterals and rearrange the pieces into a square.
- BCX and CDY are equilateral triangles inside a rectangle $ABCD$. The lines AX and AY are extended to intersect BC and CD respectively at P and Q . Show that
 - APQ is an equilateral triangle;
 - $\triangle APB + \triangle ADQ = \triangle CPQ$.

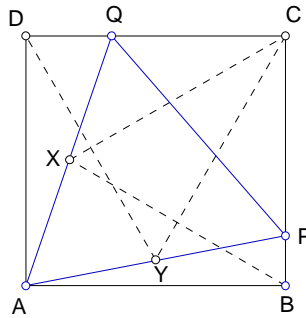

3. ABC is a triangle with a right angle at C . If the median on the side a is the geometric mean of the sides b and c , show that $c = 3b$.
4. (a) Suppose $c = a + kb$ for a right triangle with legs a, b , and hypotenuse c . Show that $0 < k < 1$, and

$$a : b : c = 1 - k^2 : 2k : 1 + k^2.$$

(b) Find two right triangles which are not similar, each satisfying $c = \frac{3}{4}a + \frac{4}{5}b$.¹

5. ABC is a triangle with a right angle at C . If the median on the side c is the geometric mean of the sides a and b , show that one of the acute angles is 15° .
6. Let ABC be a right triangle with a right angle at vertex C . Let $CXPY$ be a square with P on the hypotenuse, and X, Y on the sides. Show that the length t of a side of this square is given by

$$\frac{1}{t} = \frac{1}{a} + \frac{1}{b}.$$

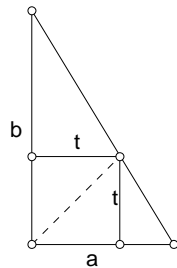

$$1/a + 1/b = 1/t.$$

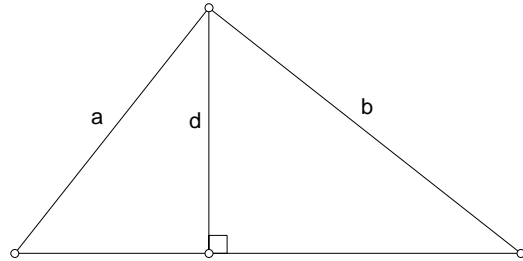

$$1/a^2 + 1/b^2 = 1/d^2.$$

¹ $a : b : c = 12 : 35 : 37$ or $12 : 5 : 13$. More generally, for $h \leq k$, there is, up to similarity, a unique right triangle satisfying $c = ha + kb$ provided

- (i) $h < 1 \leq k$, or
- (ii) $\frac{\sqrt{2}}{2} \leq h = k < 1$, or
- (iii) $h, k > 0, h^2 + k^2 = 1$.

There are two such right triangles if

$$0 < h < k < 1, \quad h^2 + k^2 > 1.$$

7. Let ABC be a right triangle with sides a , b and hypotenuse c . If d is the height of on the hypotenuse, show that

$$\frac{1}{a^2} + \frac{1}{b^2} = \frac{1}{d^2}.$$

8. (Construction of integer right triangles) It is known that every right triangle of integer sides (without common divisor) can be obtained by choosing two relatively prime positive integers m and n , one odd, one even, and setting

$$a = m^2 - n^2, \quad b = 2mn, \quad c = m^2 + n^2$$

1.2 Euclid's Proof of Pythagoras Theorem

1.2.1 Euclid's proof

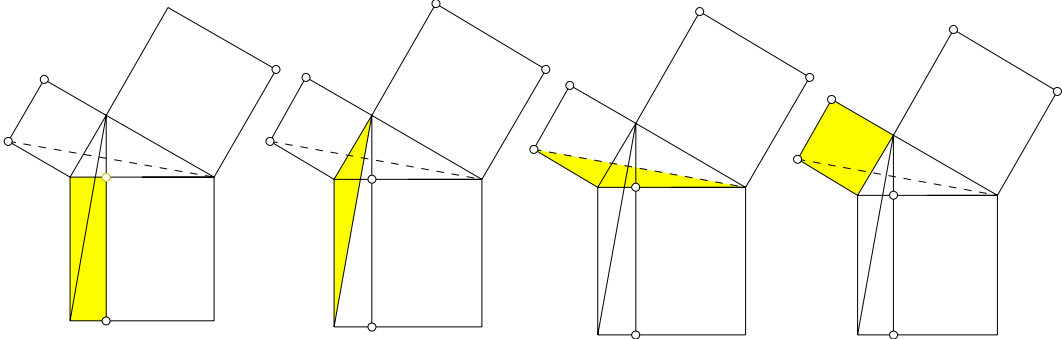

Construction 2

Given two segments of length a, b , mark three points A, P, B on a line (P between A and B) such that $PA = a, PB = b$. Describe a semicircle with AB as diameter, and let the perpendicular through P intersect the semicircle at Q . Then $PQ^2 = PA \cdot PB$, so that the length of PQ is the geometric mean of a and b .

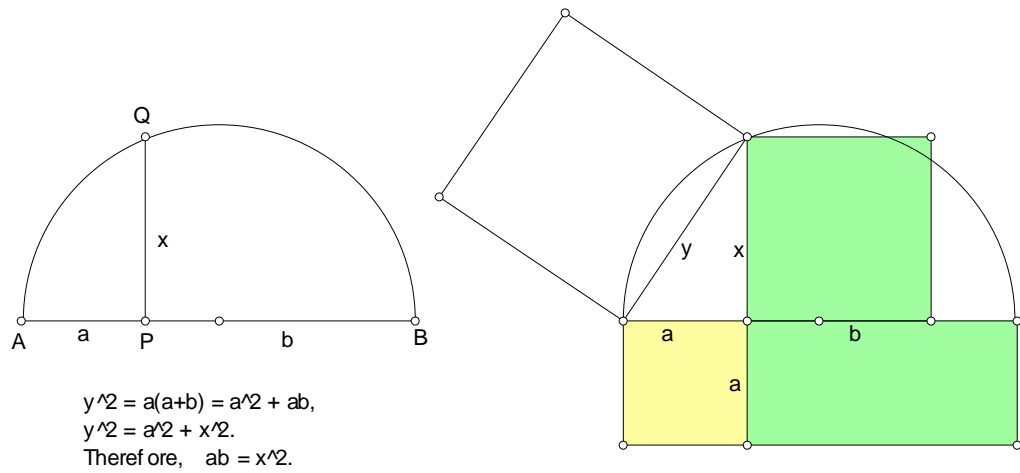

Example

To cut a given rectangle of sides $a < b$ into three pieces that can be re-arranged into a square. ²

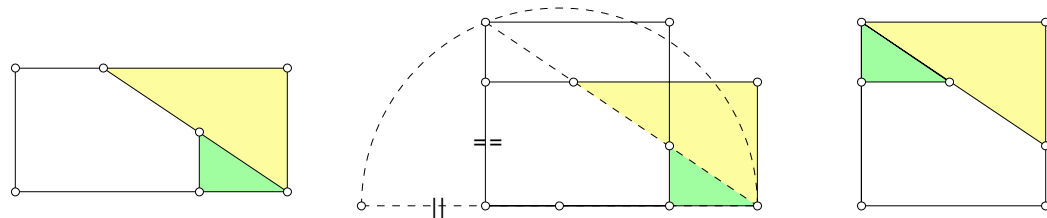

This construction is valid as long as $a \geq \frac{1}{4}b$.

²Phillips and Fisher, p.465.

Exercise

1. The midpoint of a chord of length $2a$ is at a distance d from the midpoint of the minor arc it cuts out from the circle. Show that the diameter of the circle is $\frac{a^2+d^2}{d}$.

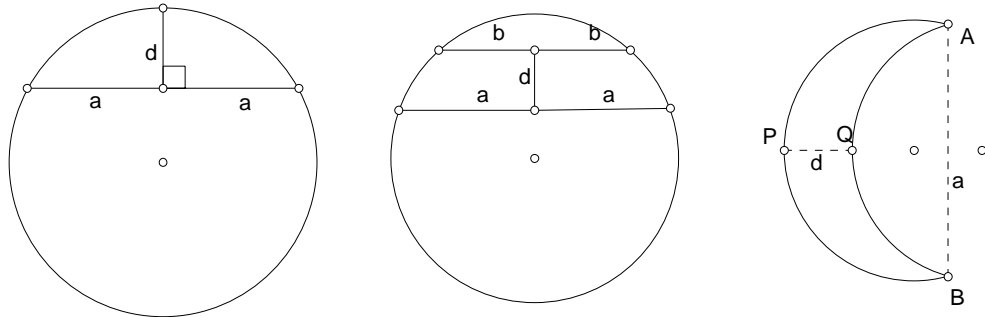

2. Two parallel chords of a circle has lengths 168 and 72, and are at a distance 64 apart. Find the radius of the circle. ³
3. A crescent is formed by intersecting two circular arcs of equal radius. The distance between the two endpoints A and B is a . The central line intersects the arcs at two points P and Q at a distance d apart. Find the radius of the circles.
4. $ABPQ$ is a rectangle constructed on the hypotenuse of a right triangle ABC . X and Y are the intersections of AB with CP and CQ respectively.

³Answer: The distance from the center to the longer chord is 13. From this, the radius of the circle is 85. More generally, if these chords has lengths $2a$ and $2b$, and the distance between them is d , the radius r of the circle is given by

$$r^2 = \frac{[d^2 + (a - b)^2][d^2 + (a + b)^2]}{4d^2}.$$

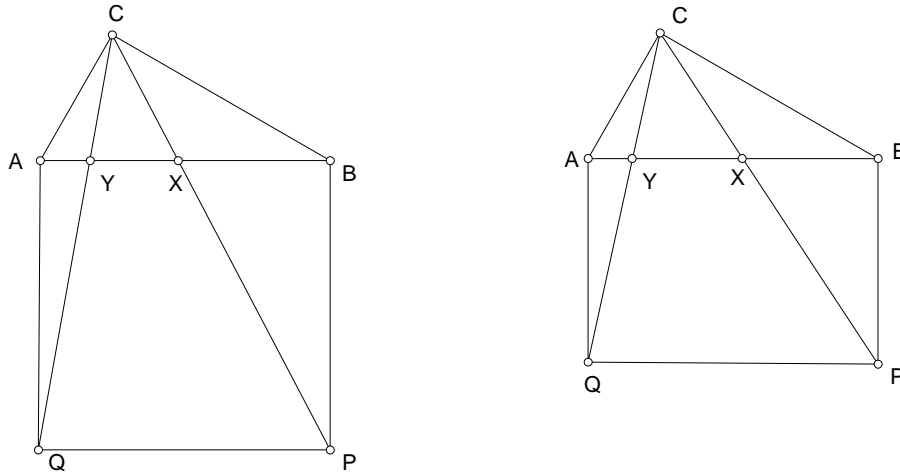

- (a) If $ABPQ$ is a square, show that $XY^2 = BX \cdot AY$.
- (b) If $AB = \sqrt{2} \cdot AQ$, show that $AX^2 + BY^2 = AB^2$.

1.3 Construction of regular polygons

1.3.1 Equilateral triangle, regular hexagon, and square

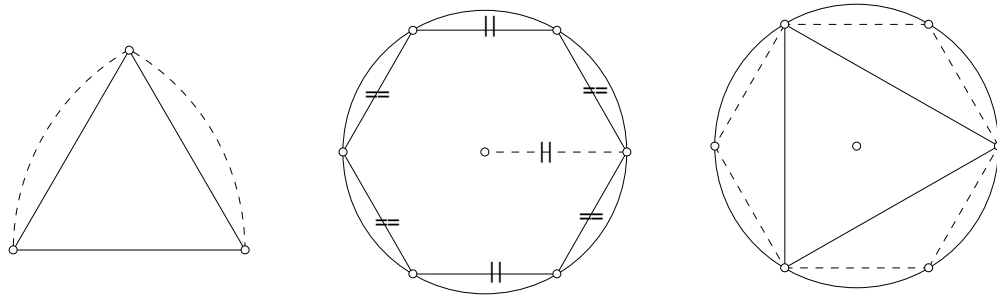

Given a circle of radius a , we denote by

z_n the length of a side of an inscribed regular n -gon.
 Z_n a circumscribed regular n -gon.

$$z_3 = \sqrt{3}a, \quad Z_3 = 2\sqrt{3}a; \quad z_4 = \sqrt{2}a, \quad Z_4 = 2a; \quad z_6 = 1, \quad Z_6 = \frac{2}{3}\sqrt{3}a.$$

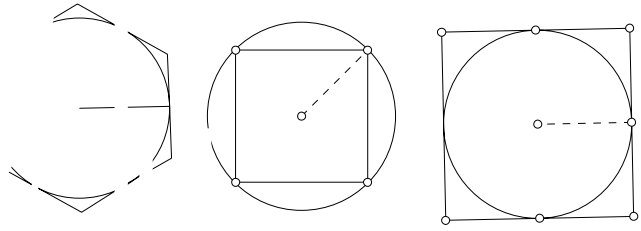

1.4 The regular pentagon and its construction

1.4.1 The regular pentagon

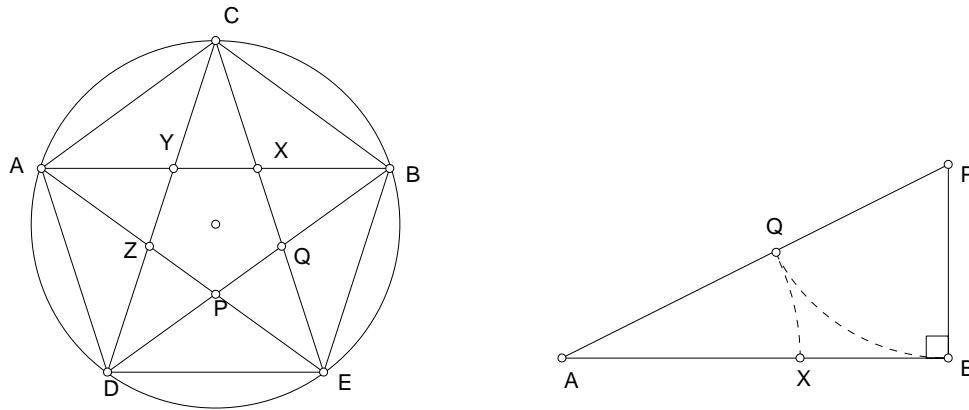

Since $XB = XC$ by symmetry, the isosceles triangles CAB and XCB are similar. From this,

$$\frac{AC}{AB} = \frac{CX}{CB},$$

and $AC \cdot CB = AB \cdot CX$. It follows that

$$AX^2 = AB \cdot XB.$$

1.4.2 Division of a segment into the golden ratio

Such a point X is said to divide the segment AB in the golden ratio, and can be constructed as follows.

(1) Draw a right triangle ABP with BP perpendicular to AB and half in length.

(2) Mark a point Q on the hypotenuse AP such that $PQ = PB$.

(3) Mark a point X on the segment AB such that $AX = AQ$.

Then X divides AB into the golden ratio, namely,

$$AX : AB = XB : AX.$$

Exercise

1. If X divides AB into the golden ratio, then $AX : XB = \phi : 1$, where

$$\phi = \frac{1}{2}(\sqrt{5} + 1) \approx 1.618 \dots$$

Show also that $\frac{AX}{AB} = \frac{1}{2}(\sqrt{5} - 1) = \phi - 1 = \frac{1}{\phi}$.

2. If the legs and the altitude of a right triangle form the sides of another right triangle, show that the altitude divides the hypotenuse into the golden ratio.
3. ABC is an isosceles triangle with a point X on AB such that $AX = CX = BC$. Show that
- $\angle BAC = 36^\circ$;
 - $AX : XB = \phi : 1$.

Suppose $XB = 1$. Let E be the midpoint of the side AC . Show that

$$XE = \frac{1}{4}\sqrt{10 + 2\sqrt{5}}.$$

Deduce that

$$\cos 36^\circ = \frac{\sqrt{5} + 1}{4}, \quad \sin 36^\circ = \frac{1}{2}\sqrt{10 - 2\sqrt{5}}, \quad \tan 36^\circ = \sqrt{5 - 2\sqrt{5}}.$$

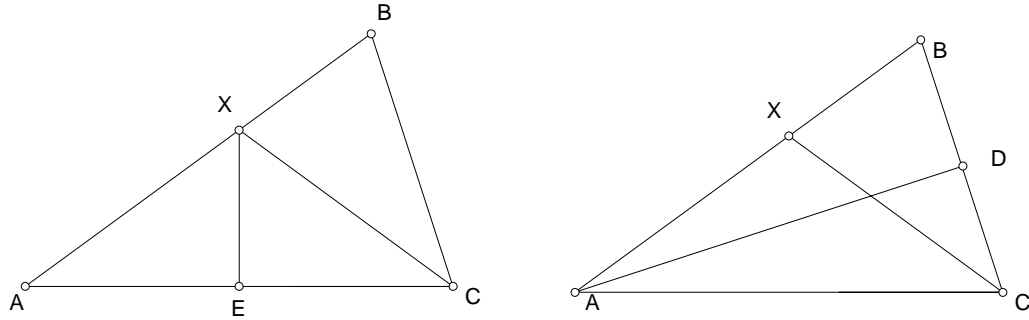

4. ABC is an isosceles triangle with $AB = AC = 4$. X is a point on AB such that $AX = CX = BC$. Let D be the midpoint of BC . Calculate the length of AD , and deduce that

$$\sin 18^\circ = \frac{\sqrt{5} - 1}{4}, \quad \cos 18^\circ = \frac{1}{4}\sqrt{10 + 2\sqrt{5}}, \quad \tan 18^\circ = \frac{1}{5}\sqrt{25 - 10\sqrt{5}}.$$

1.4.3 Construction of a regular pentagon

1. Divide a segment AB into the golden ratio at X .
2. Construct the circles $A(X)$ and $X(B)$ to intersect at C .
3. Construct a circle center C , radius AB , to meet the two circles $A(X)$ and $B(X)$ at D and E respectively.

Then, $ACBED$ is a regular pentagon.

Exercise

1. Justify the following construction of an inscribed regular pentagon.

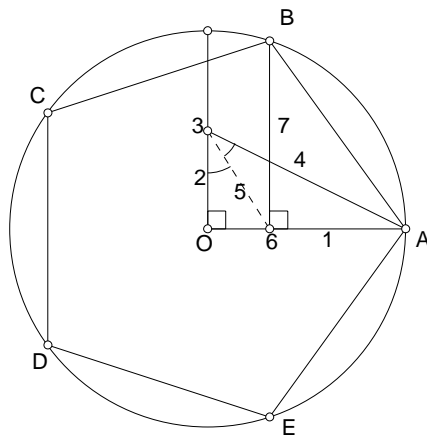

1.5 The cosine formula and its applications

1.5.1 The cosine formula

$$c^2 = a^2 + b^2 - 2ab \cos \gamma.$$

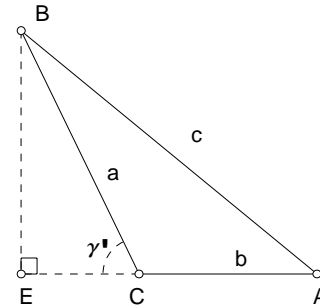
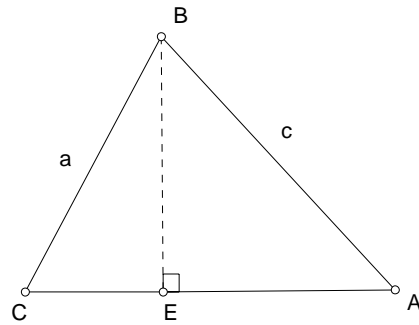

Exercise

1. Show that the (4,5,6) triangle has one angle equal to twice of another.
2. If $\gamma = 2\beta$, show that $c^2 = (a + b)b$.
3. Find a simple relation between the sum of the areas of the three squares S_1, S_2, S_3 , and that of the squares T_1, T_2, T_3 .

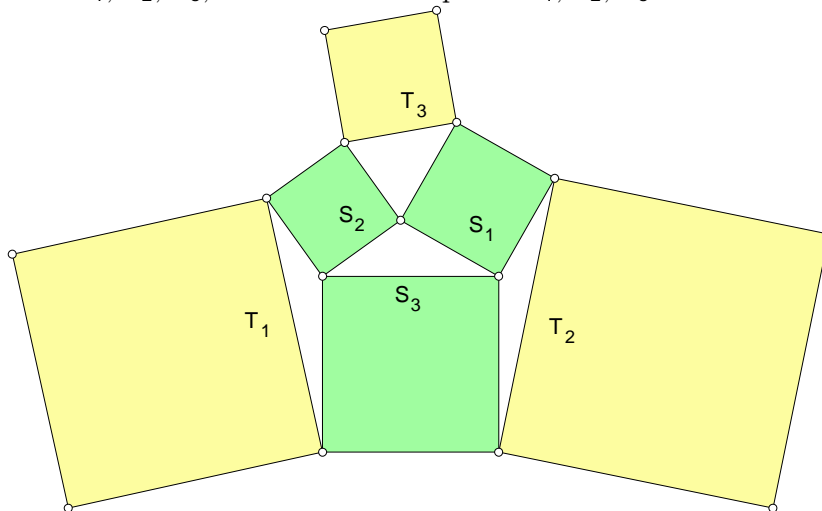

4. ABC is a triangle with $a = 12$, $b + c = 18$, and $\cos \alpha = \frac{7}{38}$. Show that

$$a^3 = b^3 + c^3.$$

⁴AMM E688, P.A. Pizá. Here, $b = 9 - \sqrt{5}$, and $c = 9 + \sqrt{5}$.

1.5.2 Stewart's Theorem

If X is a point on the side BC (or its extension) such that $BX : XC = \lambda : \mu$, then

$$AX^2 = \frac{\lambda b^2 + \mu c^2}{\lambda + \mu} - \frac{\lambda \mu a^2}{(\lambda + \mu)^2}.$$

Proof. Use the cosine formula to compute the cosines of the angles AXB and AXC , and note that $\cos ABC = -\cos AXB$.

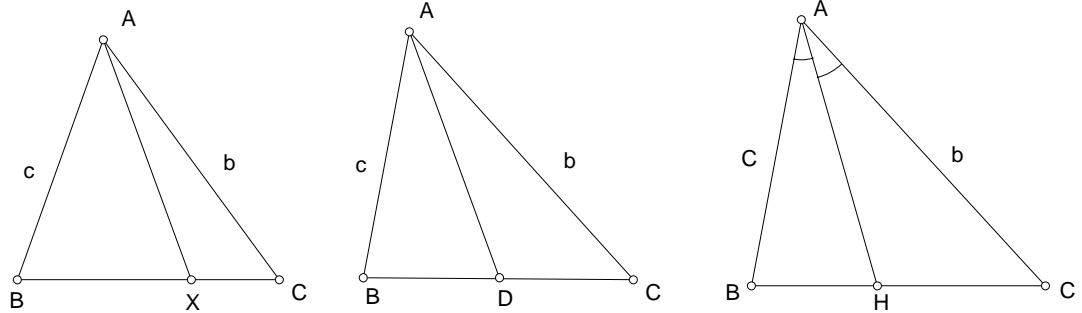

1.5.3 Apollonius Theorem

The length m_a of the median AD is given by

$$m_a^2 = \frac{1}{4}(2b^2 + 2c^2 - a^2).$$

Proof. Apply Stewart's Theorem with $\lambda = \mu = 1$.

Exercise

- $m_b = m_c$ if and only if $b = c$.
- $m_a^2 + m_b^2 + m_c^2 = \frac{3}{4}(a^2 + b^2 + c^2)$.
- The lengths of the sides of a triangle are 136, 170, and 174. Calculate the lengths of its medians.⁵
- Suppose $c^2 = \frac{a^2 + b^2}{2}$. Show that $m_c = \frac{\sqrt{3}}{2}c$. Give a euclidean construction of triangles satisfying this condition.

⁵Answers: 158, 131, 127.

5. If $m_a : m_b : m_c = a : b : c$, show that the triangle is equilateral.
6. Suppose $m_b : m_c = c : b$. Show that either
 - (i) $b = c$, or
 - (ii) the quadrilateral $AEGF$ is cyclic.
 Show that the triangle is equilateral if both (i) and (ii) hold. ⁶
7. Show that the median m_a can never be equal to the arithmetic mean of b and c . ⁷
8. The median m_a is the geometric mean of b and c if and only if $a = \sqrt{2}|b - c|$.

1.5.4 Length of angle bisector

The length w_a of the (internal) bisector of angle A is given by

$$w_a^2 = bc \left[1 - \left(\frac{a}{b+c} \right)^2 \right].$$

Proof. Apply Stewart's Theorem with $\lambda = c$ and $\mu = b$.

Exercise

1. $w_a^2 = \frac{4bcs(s-a)}{(b+c)^2}$.
2. The lengths of the sides of a triangle are 84, 125, 169. Calculate the lengths of its internal bisectors. ⁸
3. (Steiner - Lehmus Theorem) If $w_a = w_b$, then $a = b$. ⁹
4. Suppose $w_a : w_b = b : a$. Show that the triangle is either isosceles, or $\gamma = 60^\circ$. ¹⁰

⁶Cruze 383. In fact, $b^2m_b^2 - c^2m_c^2 = \frac{1}{4}(c-b)(c+b)(b^2 + c^2 - 2a^2)$.

⁷Complete the triangle ABC to a parallelogram $ABA'C$.

⁸Answers: $\frac{975}{7}$, $\frac{26208}{253}$, $\frac{12600}{209}$.

⁹Hint: Show that

$$\frac{a}{(b+c)^2} - \frac{b}{(c+a)^2} = \frac{(a-b)[(a+b+c)^2 - ab]}{(b+c)^2(c+a)^2}.$$

¹⁰ $a^2w_a^2 - b^2w_b^2 = \frac{abc(b-a)(a+b+c)^2}{(a+c)^2(b+c)^2} [a^2 - ab + b^2 - c^2]$.

5. Show that the length of the external angle bisector is given by

$$w'_a{}^2 = bc\left[\left(\frac{a}{b-c}\right)^2 - 1\right] = \frac{4bc(s-b)(s-c)}{(b-c)^2}.$$

6. In triangle ABC , $\alpha = 12^\circ$, and $\beta = 36^\circ$. Calculate the ratio of the lengths of the external angle bisectors w'_a and w'_b .¹¹

1.6 Appendix: Synthetic proofs of Steiner - Lehmus Theorem

1.6.1 First proof.¹²

Suppose $\beta < \gamma$ in triangle ABC . We show that the bisector BM is longer than the bisector CN .

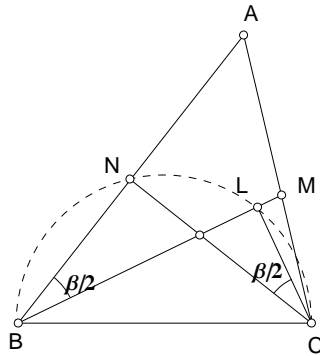

Choose a point L on BM such that $\angle NCL = \frac{1}{2}\beta$. Then B, N, L, C are concyclic since $\angle NBL = \angle NCL$. Note that

$$\angle NBC = \beta < \frac{1}{2}(\beta + \gamma) = \angle LCB,$$

and both are acute angles. Since smaller chords of a circle subtend smaller acute angles, we have $CN < BL$. It follows that $CN < BM$.

¹¹Answer: 1:1. The counterpart of the Steiner - Lehmus theorem does not hold. See Crux Math. 2 (1976) pp. 22 - 24. D.L.MacKay (AMM E312): if the external angle bisectors of B and C of a scalene triangle ABC are equal, then $\frac{s-a}{a}$ is the geometric mean of $\frac{s-b}{b}$ and $\frac{s-c}{c}$. See also Crux 1607 for examples of triangles with one internal bisector equal to one external bisector.

¹²Gilbert - McDonnell, American Mathematical Monthly, vol. 70 (1963) 79 - 80.

1.6.2 Second proof. ¹³

Suppose the bisectors BM and CN in triangle ABC are equal. We shall show that $\beta = \gamma$. If not, assume $\beta < \gamma$. Compare the triangles CBM and BCN . These have two pairs of equal sides with included angles $\angle CBM = \frac{1}{2}\beta < \frac{1}{2}\gamma = \angle BCN$, both of which are acute. Their opposite sides therefore satisfy the relation $CM < BN$.

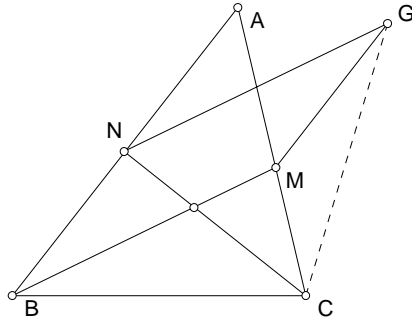

Complete the parallelogram $BMGN$, and consider the triangle CNG . This is isosceles since $CN = BM = NG$. Note that

$$\begin{aligned}\angle CGN &= \frac{1}{2}\beta + \angle CGM, \\ \angle GCN &= \frac{1}{2}\gamma + \angle GCM.\end{aligned}$$

Since $\beta <$

Chapter 2

The circumcircle and the incircle

2.1 The circumcircle

2.1.1 The circumcenter

The perpendicular bisectors of the three sides of a triangle are concurrent at the circumcenter of the triangle. This is the center of the circumcircle, the circle passing through the three vertices of the triangle.

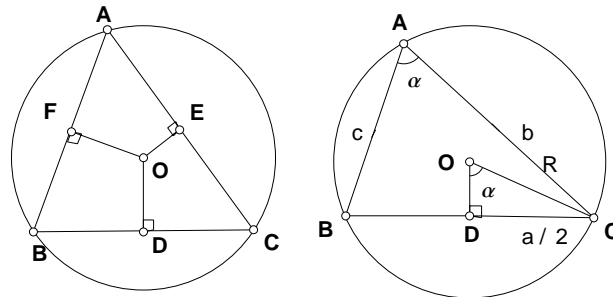

2.1.2 The sine formula

Let R denote the circumradius of a triangle ABC with sides a, b, c opposite to the angles α, β, γ respectively.

$$\frac{a}{\sin \alpha} = \frac{b}{\sin \beta} = \frac{c}{\sin \gamma} = 2R.$$

Exercise

1. The internal bisectors of angles B and C intersect the circumcircle of $\triangle ABC$ at B' and C' .
 - (i) Show that if $\beta = \gamma$, then $BB' = CC'$.
 - (ii) If $BB' = CC'$, does it follow that $\beta = \gamma$? ¹

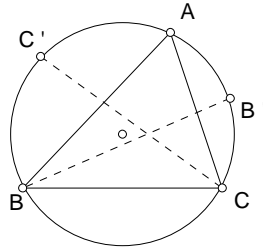

2. If H is the orthocenter of triangle ABC , then the triangles HAB , HBC , HCA and ABC have the same circumradius.
3. Given three angles α, β, γ such that $\theta + \phi + \psi = 60^\circ$, and an equilateral triangle XYZ , construct outwardly triangles AYZ and BZX such that $\angle AYZ = 60^\circ + \psi$, $\angle AZY = 60^\circ + \phi$, $\angle BZX = 60^\circ + \theta$, $\angle BXZ = 60^\circ + \psi$. Suppose the sides of XYZ have unit length.
 - (a) Show that

$$AZ = \frac{\sin(60^\circ + \psi)}{\sin \theta}, \quad \text{and} \quad BZ = \frac{\sin(60^\circ + \psi)}{\sin \phi}.$$

- (b) In triangle ABZ , show that $\angle ZAB = \theta$ and $\angle ZBA = \phi$.

¹(ii) No. $BB' = CC'$ if and only if $\beta = \gamma$ or $\alpha = \frac{2\pi}{3}$.

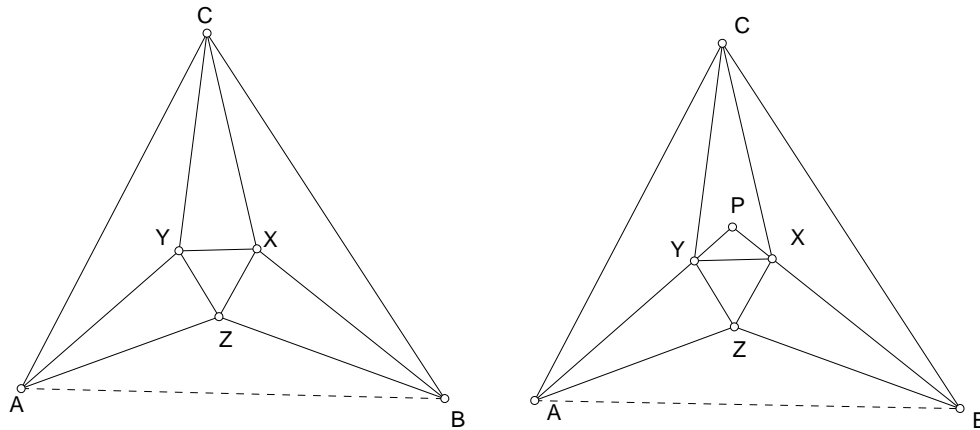

- (c) Suppose a third triangle XYC is constructed outside XYZ such that $\angle CYX = 60^\circ + \theta$ and $\angle CXY = 60^\circ + \phi$. Show that BX, BZ are the trisectors of the angles of triangle ABC .
- (d) Show that $AY \cdot BZ \cdot CX = AZ \cdot BX \cdot CY$.
- (e) Suppose the extensions of BX and AY intersect at P . Show that the triangles PXZ and PYZ are congruent.

2.1.3 Johnson's Theorem

Suppose three circles $A(r)$, $B(r)$, and $C(r)$ have a common point P . If the circles (C) and (A) intersect again at Y , then the circle through X, Y, Z also has radius r .

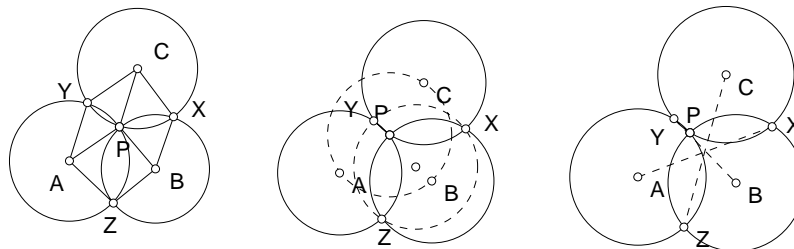

Proof. (1) $BPCX$, $APCY$ and $APBZ$ are all rhombi. Thus, AY and BX are parallel, each being parallel to PC . Since $AY = BX$, $ABXY$ is a parallelogram, and $XY = AB$.

(2) Similarly, $YZ = BC$ and $ZX = CA$. It follows that the triangles XYZ and ABC are congruent.

(3) Since triangle ABC has circumradius r , the circumcenter being P , the circumradius of XYZ is also r .

Exercise

1. Show that AX , BY and CZ have a common midpoint.

2.2 The incircle

2.2.1 The incenter

The internal angle bisectors of a triangle are concurrent at the incenter of the triangle. This is the center of the incircle, the circle tangent to the three sides of the triangle.

If the incircle touches the sides BC , CA and AB respectively at X , Y , and Z ,

$$AY = AZ = s - a, \quad BX = BZ = s - b, \quad CX = CY = s - c.$$

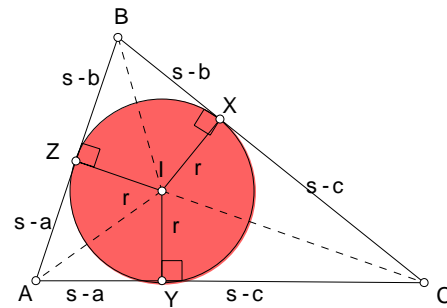
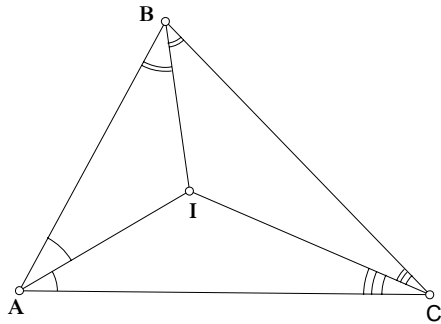

2.2.2

Denote by r the inradius of the triangle ABC .

$$r = \frac{2\Delta}{a + b + c} = \frac{\Delta}{s}.$$

Exercise

1. Show that the three small circles are equal.

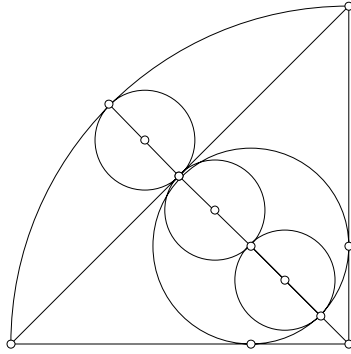

2. The incenter of a right triangle is equidistant from the midpoint of the hypotenuse and the vertex of the right angle. Show that the triangle contains a 30° angle.

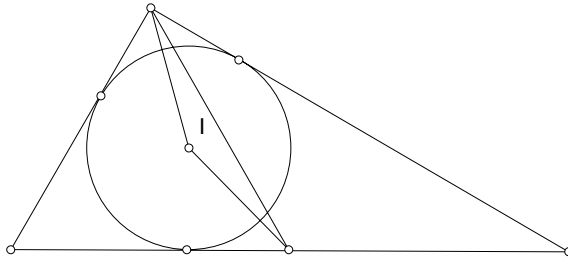

3. Show that XYZ is an acute angle triangle.
4. Let P be a point on the side BC of triangle ABC with incenter I . Mark the point Q on the side AB such that $BQ = BP$. Show that $IP = IQ$.

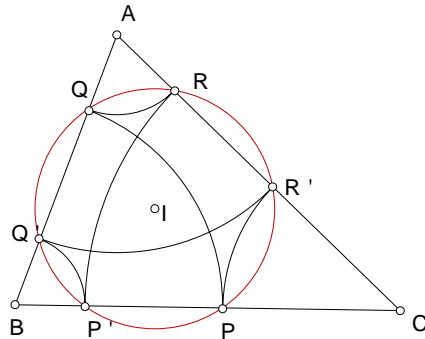

Continue to mark R on AC such that $AR = AQ$, P' on BC such that $CP' = CR$, Q' on AB such that $BQ' = BP'$, R' on AC such that $AR' = AQ'$. Show that $CP = CR'$, and that the six points P, Q, R, P', Q', R' lie on a circle, center I .

5. The inradius of a right triangle is $r = s - c$.
6. The incircle of triangle ABC touches the sides AC and AB at Y and Z respectively. Suppose $BY = CZ$. Show that the triangle is isosceles.
7. A line parallel to hypotenuse AB of a right triangle ABC passes through the incenter I . The segments included between I and the sides AC and BC have lengths 3 and 4.

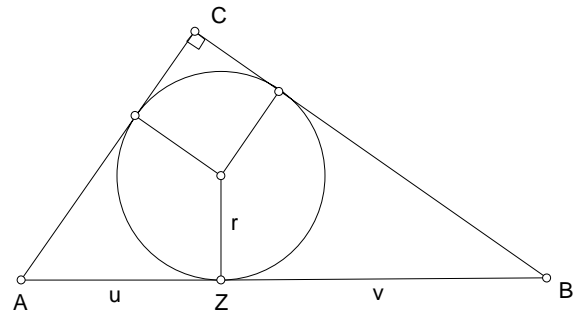
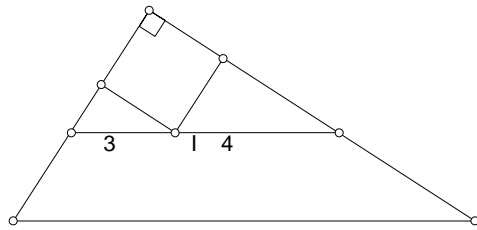

8. Z is a point on a segment AB such that $AZ = u$ and $ZB = v$. Suppose the incircle of a right triangle with AB as hypotenuse touches AB at Z . Show that the area of the triangle is equal to uv . Make use of this to give a euclidean construction of the triangle. ²

²Solution. Let r be the inradius. Since $r = s - c$ for a right triangle, $a = r + u$ and

9. AB is an arc of a circle $O(r)$, with $\angle AOB = \alpha$. Find the radius of the circle tangent to the arc and the radii through A and B .³

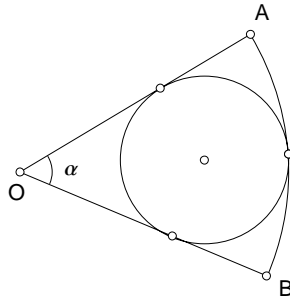

10. A semicircle with diameter BC is constructed outside an equilateral triangle ABC . X and Y are points dividing the semicircle into three equal parts. Show that the lines AX and AY divide the side BC into three equal parts.

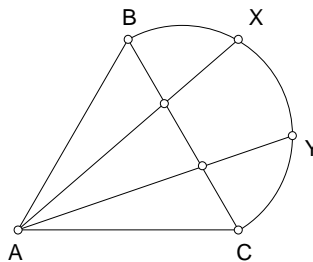

11. Suppose each side of equilateral triangle has length $2a$. Calculate the radius of the circle tangent to the semicircle and the sides AB and AC .⁴
12. AB is a diameter of a circle $O(\sqrt{5}a)$. $PXYQ$ is a square inscribed in the semicircle. Let C a point on the semicircle such that $BC = 2a$.

$b = r + v$. From $(r + u)^2 + (r + v)^2 = (u + v)^2$, we obtain $(r + u)(r + v) = 2uv$ so that the area is $\frac{1}{2}(r + u)(r + v) = uv$. If h is the height on the hypotenuse, then $\frac{1}{2}(u + v)h = uv$. This leads to a simple construction of the triangle.

³Hint: The circle is tangent to the arc at its midpoint.

⁴ $\frac{1}{3}(1 + \sqrt{3})a$.

(a) Show that the right triangle ABC has the same area as the square $PXYQ$.

(b) Find the inradius of the triangle.

find this radius. What is the inradius of each of the remaining two triangles? ⁶

15. Let the incircle $I(r)$ of a right triangle $\triangle ABC$ (with hypotenuse AB) touch its sides BC , CA , AB at X , Y , Z respectively. The bisectors AI and BI intersect the circle $Z(I)$ at the points M and N . Let CR be the altitude on the hypotenuse AB .

Show that

- (i) $XN = YM = r$;
- (ii) M and N are the incenters of the right triangles ABR and BCR respectively.

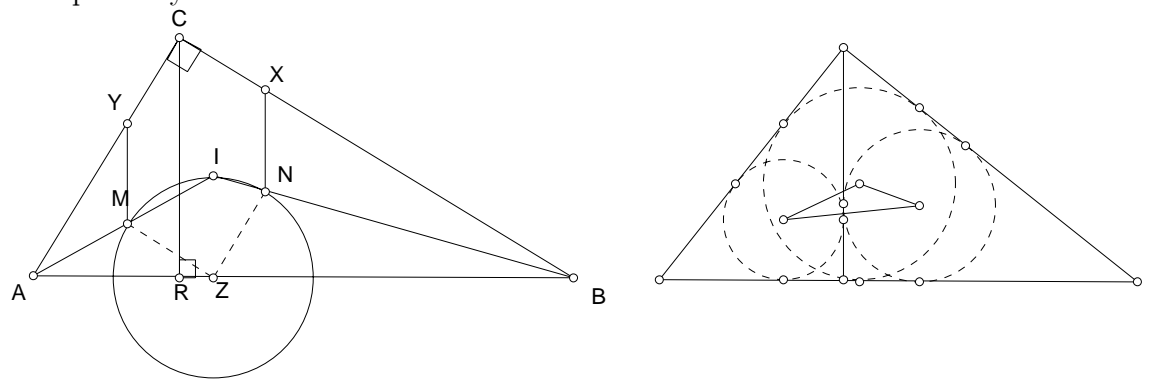

16. CR is the altitude on the hypotenuse AB of a right triangle ABC . Show that the area of the triangle determined by the incenters of triangles ABC , ACR , and BCR is $\frac{(s-c)^3}{c}$. ⁷
17. The triangle is isosceles and the three small circles have equal radii. Suppose the large circle has radius R . Find the radius of the small circles. ⁸

⁶ $(\sqrt{3} - \sqrt{2})a$.

⁷Make use of similarity of triangles.

⁸Let θ be the semi-vertical angle of the isosceles triangle. The inradius of the triangle is $\frac{2R \sin \theta \cos^2 \theta}{1 + \sin \theta} = 2R \sin \theta (1 - \sin \theta)$. If this is equal to $\frac{R}{2}(1 - \sin \theta)$, then $\sin \theta = \frac{1}{4}$. From this, the inradius is $\frac{3}{8}R$.

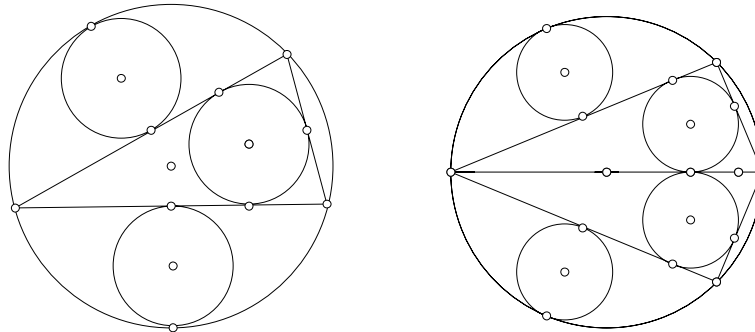

18. The large circle has radius R . The four small circles have equal radii. Find this common radius.⁹

2.3 The excircles

2.3.1 The excenter

The internal bisector of each angle and the external bisectors of the remaining two angles are concurrent at an **excenter** of the triangle. An **excircle** can be constructed with this as center, tangent to the lines containing the three sides of the triangle.

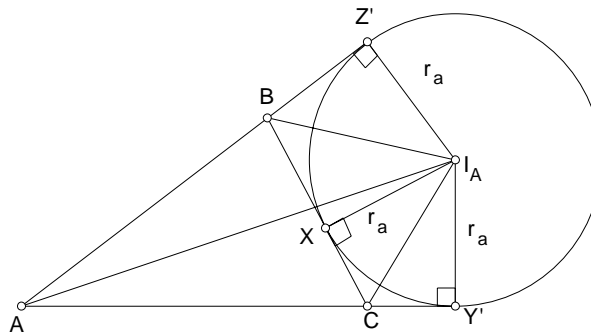

⁹Let θ be the smaller acute angle of one of the right triangles. The inradius of the right triangle is $\frac{2R \cos \theta \sin \theta}{1 + \sin \theta + \cos \theta}$. If this is equal to $\frac{R}{2}(1 - \sin \theta)$, then $5 \sin \theta - \cos \theta = 1$. From this, $\sin \theta = \frac{5}{13}$, and the inradius is $\frac{4}{13}R$.

2.3.2 The exradii

The exradii of a triangle with sides a, b, c are given by

$$r_a = \frac{\Delta}{s-a}, \quad r_b = \frac{\Delta}{s-b}, \quad r_c = \frac{\Delta}{s-c}.$$

Proof. The areas of the triangles $I_A BC$, $I_A CA$, and $I_A AB$ are $\frac{1}{2}ar_a$, $\frac{1}{2}br_a$, and $\frac{1}{2}cr_a$ respectively. Since

$$\Delta = -\Delta I_A BC + \Delta I_A CA + \Delta I_A AB,$$

we have

$$\Delta = \frac{1}{2}r_a(-a + b + c) = r_a(s - a),$$

from which $r_a = \frac{\Delta}{s-a}$.

Exercise

1. If the incenter is equidistant from the three excenters, show that the triangle is equilateral.
2. Show that the circumradius of $\triangle I_A I_B I_C$ is $2R$, and the area is $\frac{abc}{2r}$.
3. Show that for triangle ABC , if any two of the points O, I, H are concyclic with the vertices B and C , then the five points are concyclic. In this case, $\alpha = 60^\circ$.
4. Suppose $\alpha = 60^\circ$. Show that $IO = IH$.
5. Suppose $\alpha = 60^\circ$. If the bisectors of angles B and C meet their opposite sides at E and F , then $IE = IF$.
6. Show that $\frac{r}{r_a} = \tan \frac{\beta}{2} \tan \frac{\gamma}{2}$.

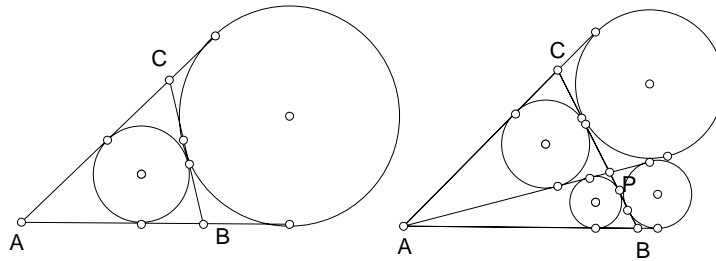

7. Let P be a point on the side BC . Denote by r', ρ' the inradius and exradius of triangle ABP and r'', ρ'' the inradius and exradius of triangle APC . Show that $\frac{r'r''}{\rho'\rho''}$ is independent of the position of P .
8. Let M be the midpoint of the arc BC of the circumcircle not containing the vertex A . Show that M is also the midpoint of the segment II_A .

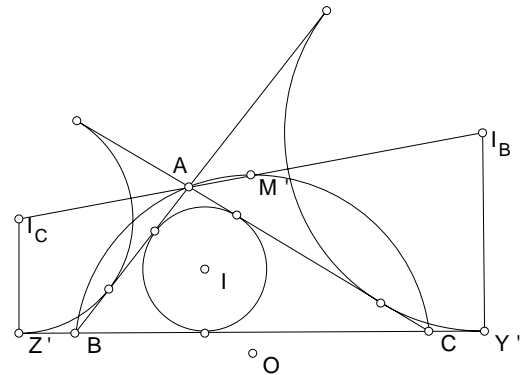
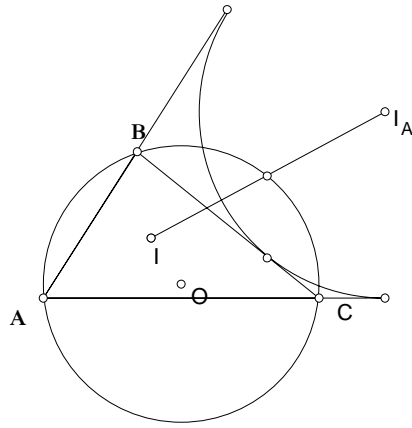

9. Let M' be the midpoint of the arc BAC of the circumcircle of triangle ABC . Show that each of $M'BI_C$ and $M'CI_B$ is an isosceles triangle. Deduce that M' is indeed the midpoint of the segment I_BI_C .
10. The circle BIC intersects the sides AC, AB at E and F respectively. Show that EF is tangent to the incircle of $\triangle ABC$.¹⁰

¹⁰Hint: Show that IF bisects angle AFE .

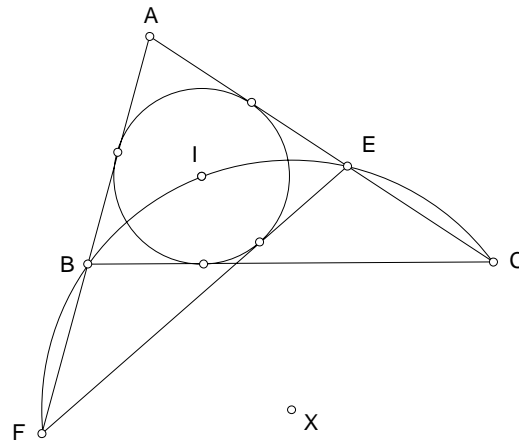

11. The incircle of triangle ABC touches the side BC at X . The line AX intersects the perpendicular bisector of BC at K . If D is the midpoint of BC , show that $DK = r_C$.

2.4 Heron's formula for the area of a triangle

Consider a triangle ABC with area Δ . Denote by r the inradius, and r_a the radius of the excircle on the side BC of triangle ABC . It is convenient to introduce the semiperimeter $s = \frac{1}{2}(a + b + c)$.

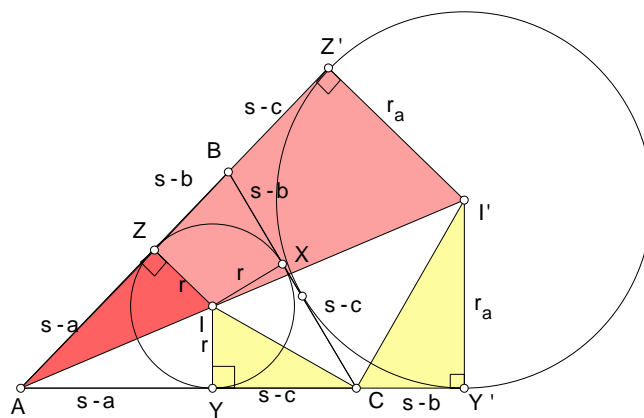

- $\Delta = rs$.

- From the similarity of triangles AIZ and $AI'Z'$,

$$\frac{r}{r_a} = \frac{s-a}{s}.$$

- From the similarity of triangles CIY and $I'CY'$,

$$r \cdot r_a = (s-b)(s-c).$$

- From these,

$$r = \sqrt{\frac{(s-a)(s-b)(s-c)}{s}},$$

$$\Delta = \sqrt{s(s-a)(s-b)(s-c)}.$$

This latter is the famous Heron formula.

Exercise

1. The altitudes a triangle are 12, 15 and 20. What is the area of the triangle ? ¹¹
2. Find the inradius and the exradii of the (13,14,15) triangle.
3. The length of each side of the square is $6a$, and the radius of each of the top and bottom circles is a . Calculate the radii of the other two circles.

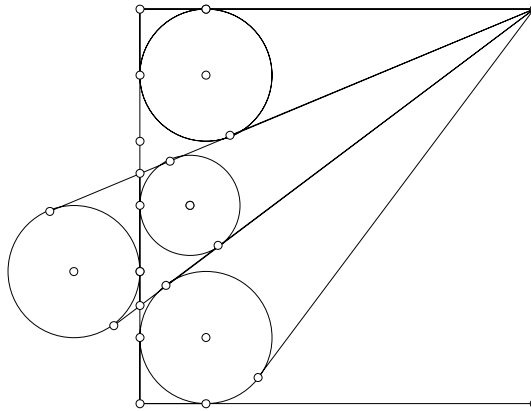

¹¹ $\Delta = 150$. The lengths of the sides are 25, 20 and 15.

4. If one of the ex-radii of a triangle is equal to its semiperimeter, then the triangle contains a right angle.
5. $\frac{1}{r_a} + \frac{1}{r_b} + \frac{1}{r_c} = \frac{1}{r}$.
6. $r_a r_b r_c = r^2 s$.
7. Show that
 - (i) $r_a + r_b + r_c = \frac{-s^3 + (ab+bc+ca)s}{\Delta}$;
 - (ii) $(s-a)(s-b)(s-c) = -s^3 + (ab+bc+ca)s$.
 Deduce that

$$r_a + r_b + r_c = 4R + r.$$

2.4.1 Appendix: A synthetic proof of $r_a + r_b + r_c = 4R + r$

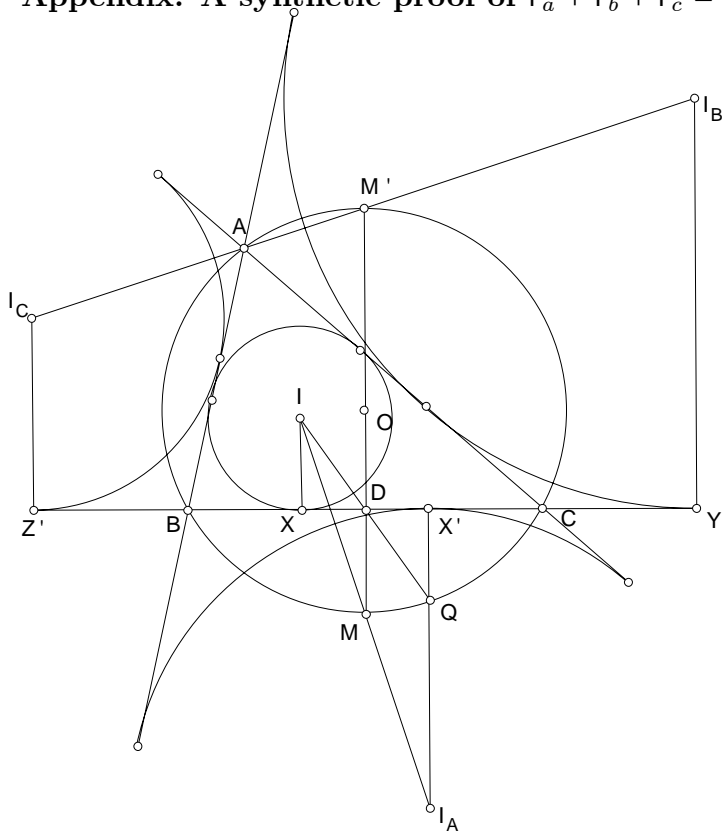

- Proof. (1) The midpoint M of the segment II_A is on the circumcircle.
(2) The midpoint M' of $I_B I_C$ is also on the circumcircle.
(3) MM' is indeed a diameter of the circumcircle, so that $MM' = 2R$.
(4) If D is the midpoint of BC , then $DM' = \frac{1}{2}(r_b + r_c)$.
(5) Since D is the midpoint of XX' , $QX' = IX = r$, and $I_A Q = r_a - r$.
(6) Since M is the midpoint of II_A , MD is parallel to $I_A Q$ and is half in length. Thus, $MD = \frac{1}{2}(r_a - r)$.
(7) It now follows from $MM' = 2R$ that $r_a + r_b + r_c - r = 4R$.

Chapter 3

The Euler line and the nine-point circle

3.1 The orthocenter

3.1.1

The three altitudes of a triangle are concurrent. The intersection is the orthocenter of the triangle.

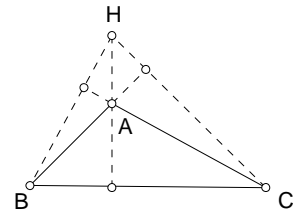
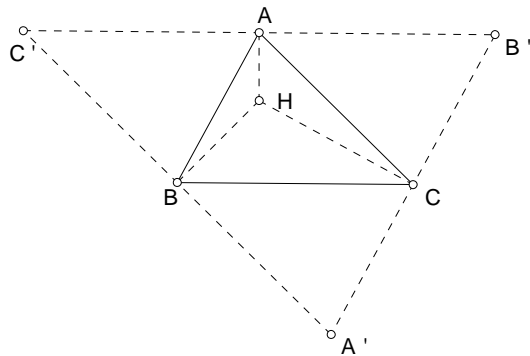

The orthocenter of a triangle is the circumcenter of the triangle bounded by the lines through the vertices parallel to their opposite sides.

3.1.2

The orthocenter of a right triangle is the vertex of the right angle.

If the triangle is obtuse, say, $\alpha > 90^\circ$, then the orthocenter H is outside the triangle. In this case, C is the orthocenter of the acute triangle ABH .

3.1.3 Orthocentric quadrangle

More generally, if A, B, C, D are four points one of which is the orthocenter of the triangle formed by the other three, then each of these points is the orthocenter of the triangle whose vertices are the remaining three points. In this case, we call $ABCD$ an orthocentric quadrangle.

3.1.4 Orthic triangle

The orthic triangle of ABC has as vertices the traces of the orthocenter H on the sides. If ABC is an acute triangle, then the angles of the orthic triangle are

$$180^\circ - 2\alpha, \quad 180^\circ - 2\beta, \quad \text{and} \quad 180^\circ - 2\gamma.$$

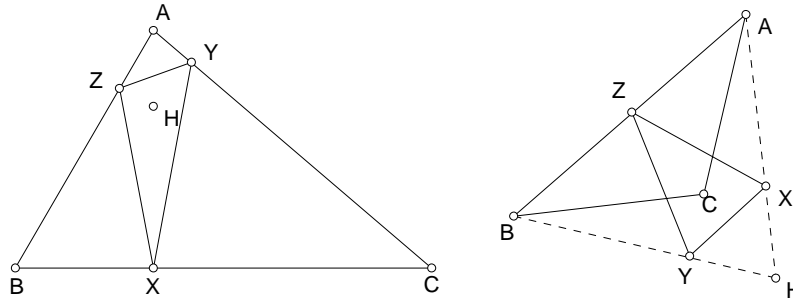

If ABC is an obtuse triangle, with $\gamma > 90^\circ$, then ABH is acute, with angles $90^\circ - \beta$, $90^\circ - \alpha$, and $180^\circ - \gamma$. The triangles ABC and ABH have the same orthic triangle, whose angles are then

$$2\beta, \quad 2\alpha, \quad \text{and} \quad 2\gamma - 180^\circ.$$

Exercise

1. If ABC is an acute triangle, then $YZ = a \cos \alpha$. How should this be modified if $\alpha > 90^\circ$?
2. If an acute triangle is similar to its orthic triangle, then the triangle must be equilateral.

3. Let H be the orthocenter of an acute triangle. $AH = 2R \cdot \cos \alpha$, and $HX = 2R \cdot \cos \beta \cos \gamma$, where R is the circumradius.
4. If an obtuse triangle is similar to its orthic triangle, find the angles of the triangle. ¹

3.2 The Euler line

3.2.1 Theorem

The circumcenter O , the orthocenter H and the median point M of a non-equilateral triangle are always collinear. Furthermore, $OG : GH = 1 : 2$.

Proof. Let Y be the projection of the orthocenter H on the side AC .

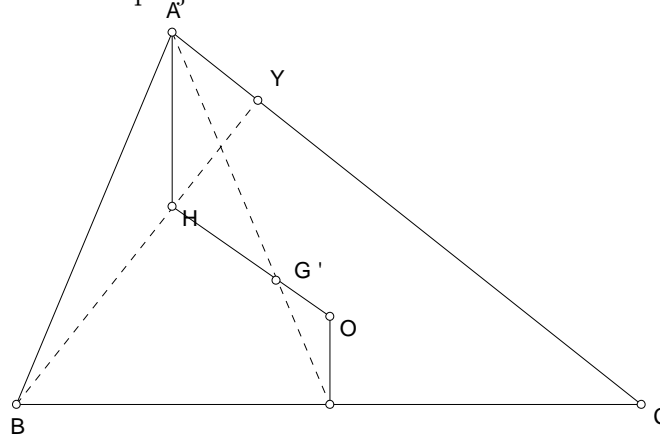

The Euler line

1. $AH = AY / \sin \gamma = c \cos \alpha / \sin \gamma = 2R \cos \alpha$.
2. $OD = R \cos \alpha$.
3. If OH and AD intersect at G' , then $\triangle AG'H \simeq \triangle DG'O$, and $AG' = 2G'D$.
4. Consequently, $G' = G$, the centroid of $\triangle ABC$.

The line OGH is called the Euler line of the triangle.

¹ $\frac{180^\circ}{7}$, $\frac{360^\circ}{7}$, and $\frac{720^\circ}{7}$.

Exercise

1. Show that a triangle is equilateral if and only if any two of the points coincide.

circumcenter, incenter, centroid, orthocenter.

2. Show that the incenter I of a non-equilateral triangle lies on the Euler line if and only if the triangle is isosceles.
3. Let O be the circumcenter of $\triangle ABC$. Denote by D, E, F the projections of O on the sides BC, CA, AB respectively. DEF is called the medial triangle of ABC .
 - (a) Show that the orthocenter of DEF is the circumcenter O of $\triangle ABC$.
 - (b) Show that the centroid of DEF is the centroid of $\triangle ABC$.
 - (c) Show that the circumcenter N of DEF also lies on the Euler line of $\triangle ABC$. Furthermore,

$$OG : GN : NH = 2 : 1 : 3.$$

4. Let H be the orthocenter of triangle ABC . Show that the Euler lines of $\triangle ABC, \triangle HBC, \triangle HCA$ and $\triangle HAB$ are concurrent.²
5. Show that the Euler line is parallel (respectively perpendicular) to the internal bisector of angle C if and only if $\gamma = \frac{2\pi}{3}$ (respectively $\frac{\pi}{3}$).
6. A diameter d of the circumcircle of an equilateral triangle ABC intersects the sides BC, CA and AB at D, E and F respectively. Show that the Euler lines of the triangles AEF, BFD and CDE form an equilateral triangle symmetrically congruent to ABC , the center of symmetry lying on the diameter d .³

²Hint: find a point common to them all.

³Thébault, AMM E547.

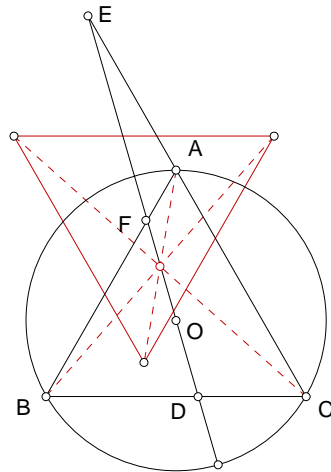

7. The Euler lines of triangles IBC , ICA , IAB are concurrent.⁴

3.3 The nine-point circle

Let ABC be a given triangle, with

- (i) D, E, F the midpoints of the sides BC, CA, AB ,
- (ii) P, Q, R the projections of the vertices A, B, C on their opposite sides, the altitudes AP, BQ, CR concurring at the orthocenter H ,
- (iii) X, Y, Z the midpoints of the segments AH, BH, CH .

The nine points $D, E, F, P, Q, R, X, Y, Z$ are concyclic.

This is called the **nine-point circle** of $\triangle ABC$. The center of this circle is the nine-point center F . It is indeed the circumcircle of the **medial triangle** DEF .

The center F of the nine-point circle lies on the Euler line, and is the midway between the circumcenter O and the orthocenter H .

⁴Crux 1018. Schliffer-Veldkamp.

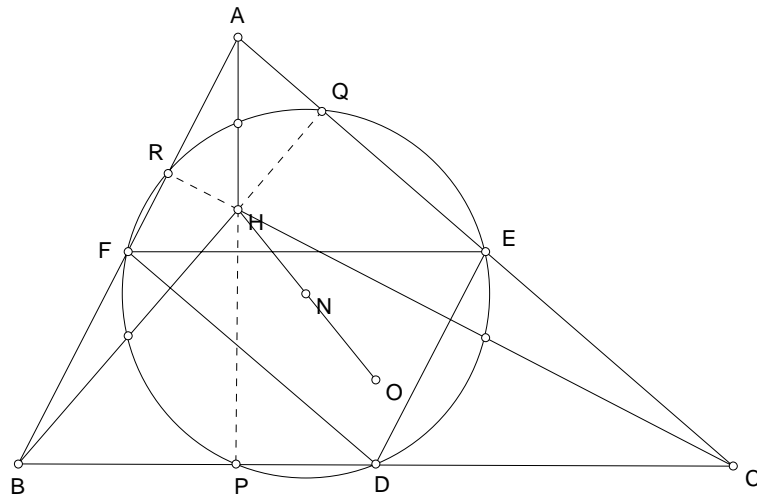

The nine-point circle of a triangle

Exercise

1. P and Q are two points on a semicircle with diameter AB . AP and BQ intersect at C , and the tangents at P and Q intersect at X . Show that CX is perpendicular to AB .

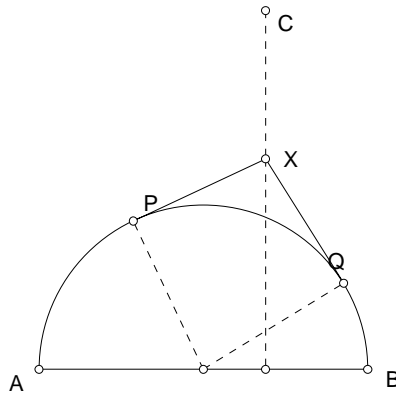

2. Let P be a point on the circumcircle of triangle ABC , with orthocenter H . The midpoint of PH lies on the nine-point circle of the triangle. ⁵

3. (a) Let ABC be an isosceles triangle with $a = 2$ and $b = c = 9$. Show that there is a circle with center I tangent to each of the excircles of triangle ABC .
 - (b) Suppose there is a circle with center I tangent externally to each of the excircles. Show that the triangle is equilateral.
 - (c) Suppose there is a circle with center I tangent internally to each of the excircles. Show that the triangle is equilateral.
4. Prove that the nine-point circle of a triangle trisects a median if and only if the side lengths are proportional to its medians lengths in some order.

3.4 Power of a point with respect to a circle

The power of a point P with respect to a circle $O(r)$ is defined as

$$O(r)_P := OP^2 - r^2.$$

This number is positive, zero, or negative according as P is outside, on, or inside the circle.

3.4.1

For any line ℓ through P intersecting a circle (O) at A and B , the signed product $PA \cdot PB$ is equal to $(O)_P$, the power of P with respect to the circle (O) .

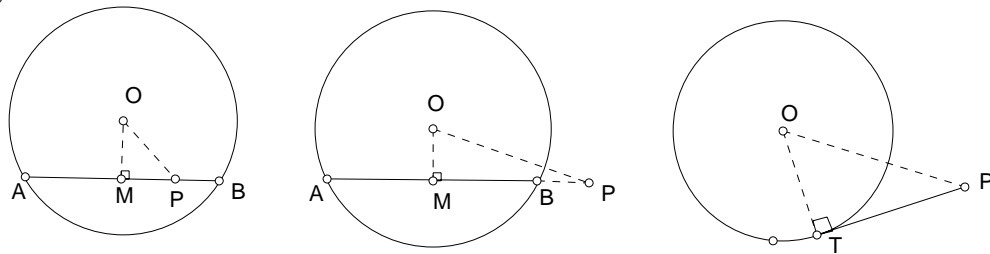

If P is outside the circle, $(O)_P$ is the square of the tangent from P to (O) .

3.4.2 Theorem on intersecting chords

If two lines containing two chords AB and CD of a circle (O) intersect at P , the signed products $PA \cdot PB$ and $PC \cdot PD$ are equal.

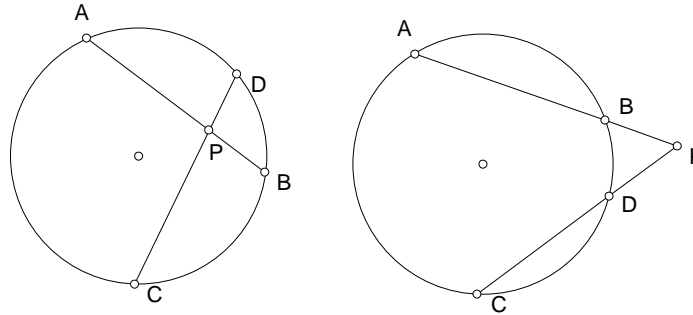

Proof. Each of these products is equal to the power $(O)_P = OP^2 - r^2$.

Exercise

1. If two circles intersect, the common chord, when extended, bisects the common tangents.

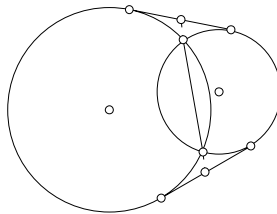

2. E and F are the midpoints of two opposite sides of a square $ABCD$. P is a point on CE , and FQ is parallel to AE . Show that PQ is tangent to the incircle of the square.

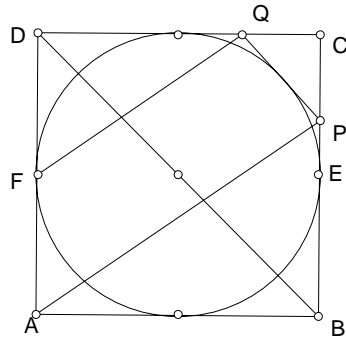

3. (The butterfly theorem) Let M be the midpoint of a chord AB of a circle (O). PY and QX are two chords through M . PX and QY intersect the chord AB at H and K respectively.

(i) Use the sine formula to show that

$$\frac{HX \cdot HP}{HM^2} = \frac{KY \cdot KQ}{KM^2}.$$

(ii) Use the intersecting chords theorem to deduce that $HM = KM$.

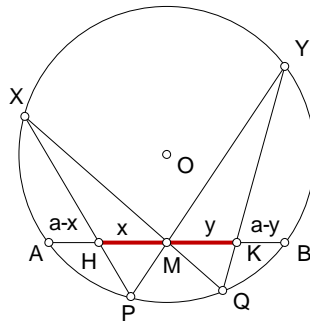

4. P and Q are two points on the diameter AB of a semicircle. $K(T)$ is the circle tangent to the semicircle and the perpendiculars to AB at P and Q . Show that the distance from K to AB is the geometric mean of the lengths of AP and BQ .

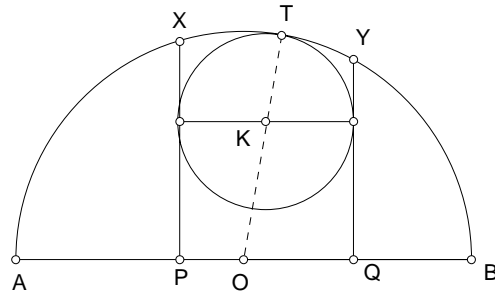

3.5 Distance between O and I

3.5.1 Theorem

The distance d between the circumcenter O and the incenter I of $\triangle ABC$ is given by

$$R^2 - d^2 = 2Rr.$$

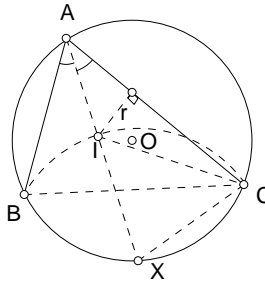

Proof. Join AI to cut the circumcircle at X . Note that X is the midpoint of the arc BC . Furthermore,

1. $IX = XB = XC = 2R \sin \frac{\alpha}{2}$,
2. $IA = r / \sin \frac{\alpha}{2}$, and
3. $R^2 - d^2 = \text{power of } I \text{ with respect to the circumcircle} = IA \cdot IX = 2Rr$.

3.5.2 Corollary

$$r = 4R \sin \frac{\alpha}{2} \sin \frac{\beta}{2} \sin \frac{\gamma}{2}.$$

Proof. Note that triangle XIC is isosceles with $\angle IXC = \beta$. This means $IC = 2XC \cdot \sin \frac{\beta}{2} = 4R \sin \frac{\alpha}{2} \sin \frac{\beta}{2}$. It follows that

$$r = IC \cdot \sin \frac{\gamma}{2} = 4R \sin \frac{\alpha}{2} \sin \frac{\beta}{2} \sin \frac{\gamma}{2}.$$

3.5.3 Distance between O and excenters

$$OI_A^2 = R^2 + 2Rr_a.$$

Exercise

1. Given the circumcenter, the incenter, and a vertex of a triangle, to construct the triangle.
2. Given a circle $O(R)$ and $r < \frac{1}{2}R$, construct a point I inside $O(R)$ so that $O(R)$ and $I(r)$ are the circumcircle and incircle of a triangle?
3. Given a point I inside a circle $O(R)$, construct a circle $I(r)$ so that $O(R)$ and $I(r)$ are the circumcircle and incircle of a triangle?
4. Given a circle $I(r)$ and a point O , construct a circle $O(R)$ so that $O(R)$ and $I(r)$ are the circumcircle and incircle of a triangle?
5. Show that the line joining the circumcenter and the incenter is parallel to a side of the triangle if and only if one of the following condition holds.
 - (a) One of the angles has cosine $\frac{r}{R}$;
 - (b) $s^2 = \frac{(2R-r)^2(R+r)}{R-r}$.
6. The power of I with respect to the circumcircle is $\frac{abc}{a+b+c}$.⁶
7. $\angle AIO \leq 90^\circ$ if and only if $2a \leq b + c$.
8. Make use of the relation

$$a = r \left(\cot \frac{\beta}{2} + \cot \frac{\gamma}{2} \right)$$

to give an alternative proof of the formula $r = 4R \sin \frac{\alpha}{2} \sin \frac{\beta}{2} \sin \frac{\gamma}{2}$.

9. Show that $XI_A = XI$.

⁶Johnson, §298(i). This power is $OI^2 - R^2 = 2Rr = \frac{abc}{2\Delta} \cdot \frac{\Delta}{s} = \frac{abc}{2s}$.

Chapter 4

Circles

4.1 Tests for concyclic points

4.1.1

Let A, B, C, D be four points such that the lines AB and CD intersect (extended if necessary) at P . If $AP \cdot BP = CP \cdot DP$, then the points A, B, C, D are concyclic.

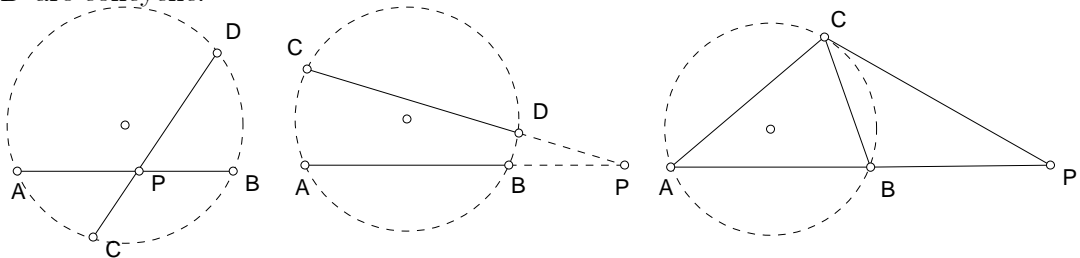

4.1.2

Let P be a point on the line containing the side AB of triangle ABC such that $AP \cdot BP = CP^2$. Then the line CP touches the circumcircle of triangle ABC at the point C .

Exercise

1. Let ABC be a triangle satisfying $\gamma = 90^\circ + \frac{1}{2}\beta$. If Z is the point on the side AB such that $BZ = BC = a$, then the circumcircle of triangle

BCZ touches the side AC at C .

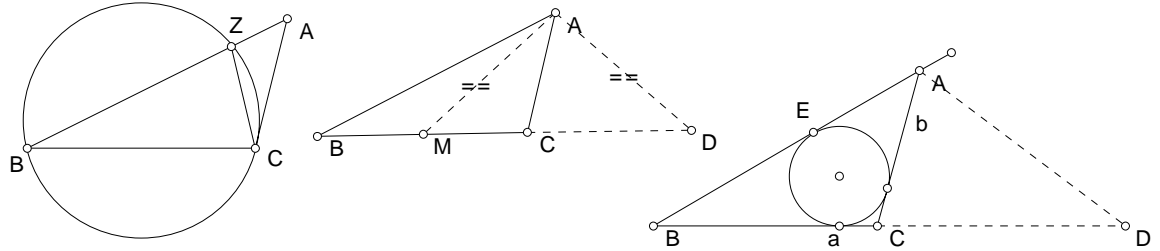

2. Let ABC be a triangle satisfying $\gamma = 90^\circ + \frac{1}{2}\beta$. Suppose that M is the midpoint of BC , and that the circle with center A and radius AM meets BC again at D . Prove that $MD = AB$.
3. Suppose that ABC is a triangle satisfying $\gamma = 90^\circ + \frac{1}{2}\beta$, that the exterior bisector of angle A intersects BC at D , and that the side AB touches the incircle of triangle ABC at F . Prove that $CD = 2AF$.

4.2 Tangents to circles

The centers of the two circles $A(a)$ and $A(b)$ are at a distance d apart. Suppose $d > a + b$ so that the two circles do not intersect. The internal common tangent PQ has length

$$\sqrt{d^2 - (a + b)^2}.$$

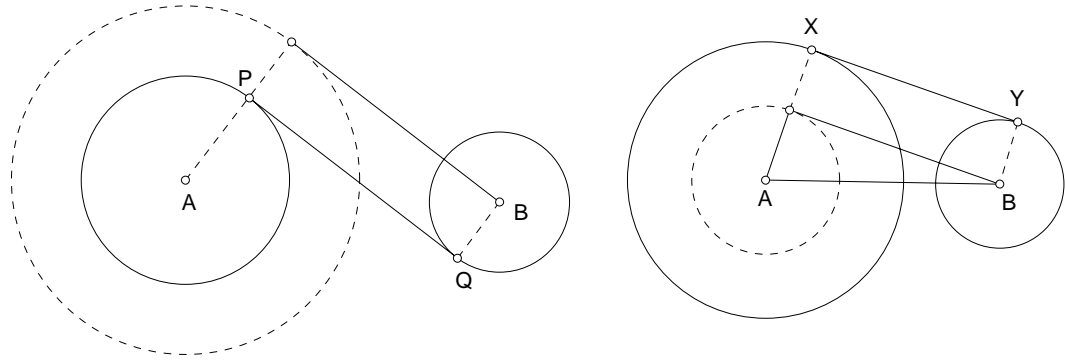

Suppose $d > |a - b|$ so that none of the circle contains the other. The external common tangent XY has length

$$\sqrt{d^2 - (a - b)^2}.$$

Exercise

- In each of the following cases, find the ratio $AB : BC$.¹

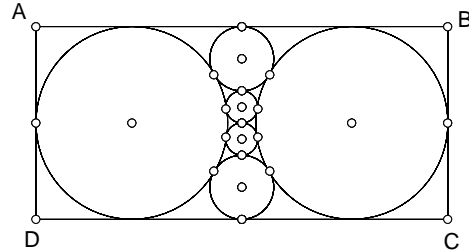
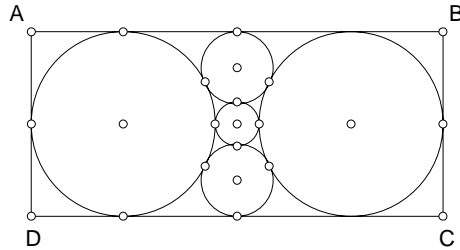

- Two circles $A(a)$ and $B(b)$ are tangent externally at a point P . The common tangent at P intersects the two external common tangents $XY, X'Y'$ at K, K' respectively.
 - Show that $\angle AKB$ is a right angle.
 - What is the length PK ?
 - Find the lengths of the common tangents XY and KK' .

¹ $\sqrt{3} : \sqrt{3} + 2$ in the case of 4 circles.

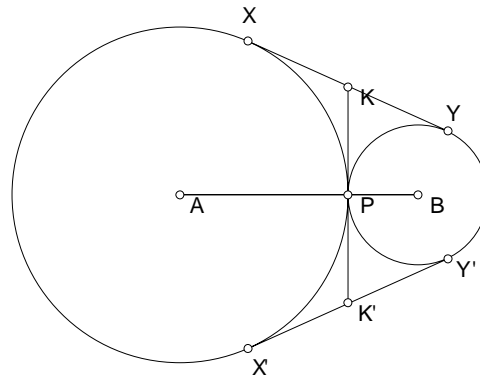

3. $A(a)$ and $B(b)$ are two circles with their centers at a distance d apart. AP and AQ are the tangents from A to circle $B(b)$. These tangents intersect the circle $A(a)$ at H and K . Calculate the length of HK in terms of d , a , and b .²

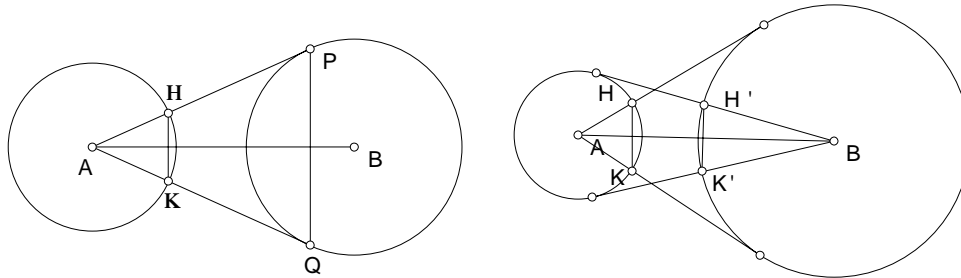

4. Tangents are drawn from the center of two given circles to the other circles. Show that the chords HK and $H'K'$ intercepted by the tangents are equal.
5. $A(a)$ and $B(b)$ are two circles with their centers at a distance d apart. From the extremity A' of the diameter of $A(a)$ on the line AB , tangents are constructed to the circle $B(b)$. Calculate the radius of the circle tangent internally to $A(a)$ and to these tangent lines.³

² Answer: $\frac{2ab}{d}$.

³ Answer: $\frac{2ab}{d+a+b}$.

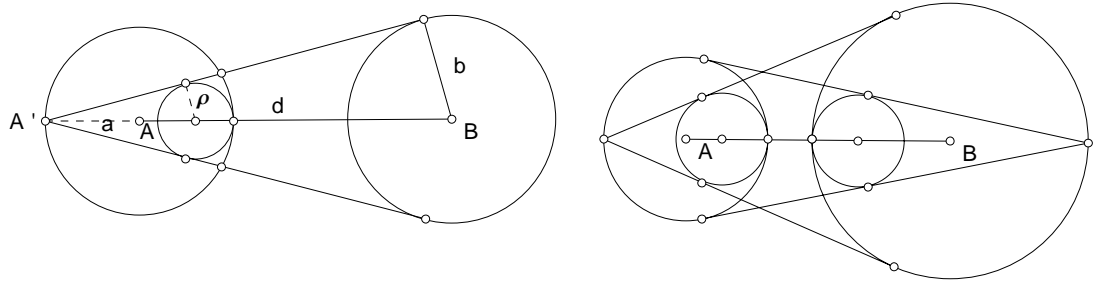

6. Show that the two incircles have equal radii.
7. $ABCD$ is a square of unit side. P is a point on BC so that the incircle of triangle ABP and the circle tangent to the lines AP , PC and CD have equal radii. Show that the length of BP satisfies the equation

$$2x^3 - 2x^2 + 2x - 1 = 0.$$

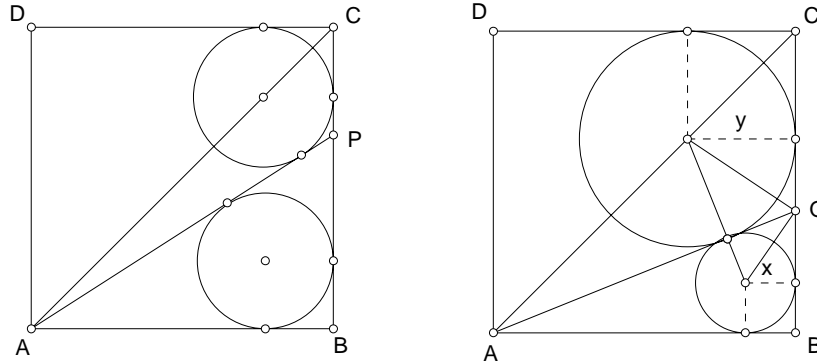

8. $ABCD$ is a square of unit side. Q is a point on BC so that the incircle of triangle ABQ and the circle tangent to AQ , QC , CD touch each other at a point on AQ . Show that the radii x and y of the circles satisfy the equations

$$y = \frac{x(3 - 6x + 2x^2)}{1 - 2x^2}, \quad \sqrt{x} + \sqrt{y} = 1.$$

Deduce that x is the root of

$$4x^3 - 12x^2 + 8x - 1 = 0.$$

4.3 Tangent circles

4.3.1 A basic formula

Let AB be a chord of a circle $O(R)$ at a distance h from the center O , and P a point on AB . The radii of the circles $K(r)$ $K'(r')$ tangent to AB at P and also to the ^{minor} _{major} arc AB are

$$r = \frac{AP \cdot PB}{2(R + h)} \quad \text{and} \quad r' = \frac{AP \cdot PB}{2(R - h)}$$

respectively.

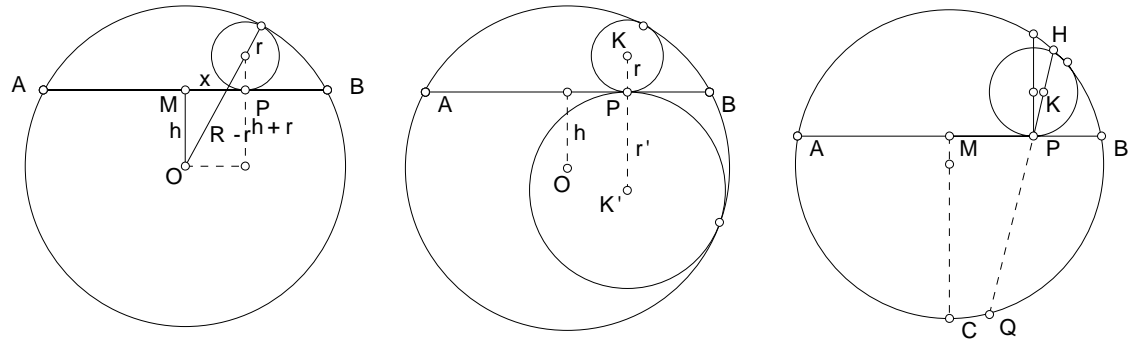

Proof. Let M be the midpoint of AB and $MP = x$. Let $K(r)$ be the circle tangent to AB at P and to the minor arc AB . We have

$$(R - r)^2 = x^2 + (h + r)^2,$$

from which

$$r = \frac{R^2 - x^2 - h^2}{2(R + h)} = \frac{R^2 - OP^2}{2(R + h)} = \frac{AP \cdot PB}{2(R + h)}.$$

The case for the major arc is similar.

4.3.2 Construction

Let C be the midpoint of arc AB . Mark a point Q on the circle so that $PQ = CM$. Extend QP to meet the circle again at H . Then $r = \frac{1}{2}PH$, from this the center K can be located easily.

Remarks

(1) If the chord AB is a diameter, these two circles both have radius

$$\frac{AP \cdot PB}{2R}.$$

(2) Note that the ratio $r : r' = R - h : R + h$ is independent of the position of P on the chord AB .

4.3.3

Let θ be the angle between an external common tangent of the circles $K(r)$, $K'(r')$ and the center line KK' . Clearly,

$$\sin \theta = \frac{r' - r}{r' + r} = \frac{1 - \frac{r}{r'}}{1 + \frac{r}{r'}} = \frac{1 - \frac{R-h}{R+h}}{1 + \frac{R-h}{R+h}} = \frac{h}{R}.$$

This is the same angle between the radius OA and the chord AB . Since the center line KK' is perpendicular to the chord AB , the common tangent is perpendicular to the radius OA . This means that A is the midpoint of the minor arc cut out by an external common tangent of the circles (K) and (K') .

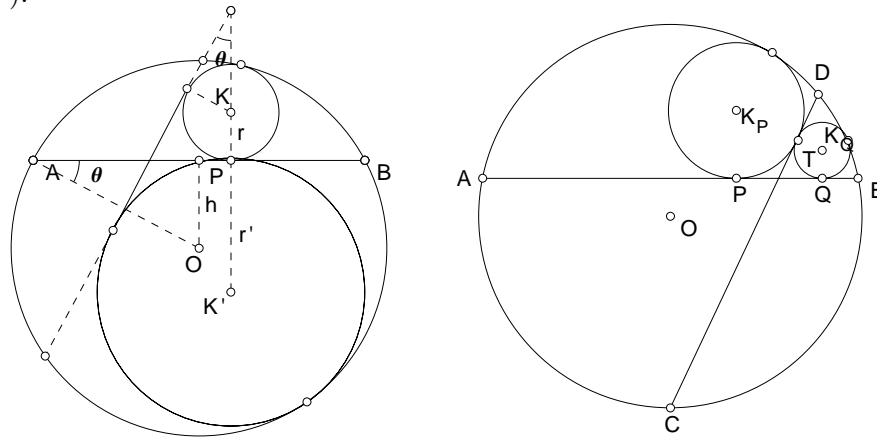

4.3.4

Let P and Q be points on a chord AB such that the circles (K_P) and (K_Q) , each being tangent to the chord and the minor arc AB , are also tangent to the major arc AB .

each other externally. Then the internal common tangent of the two circles passes through the midpoint of the $\begin{matrix} \text{major} \\ \text{minor} \end{matrix}$ arc AB .

Proof. Let T be the point of contact, and CD the chord of (O) which is the internal common tangent of the circles $K(P)$ and $K(Q)$. Regarding these two circles are tangent to the chord CD , and AB as an external common tangent, we conclude that C is the midpoint of the arc AB .

4.3.5

This leads to a simple construction of the two neighbors of (K_P) , each tangent to (K_P) , to the chord AB , and to the arc AB containing K_P .

Given a circle (K_P) tangent to (O) and a chord AB , let C be the midpoint of the arc not containing K_P .

- (1) Construct the tangents from CT and CT' to the circle (K_P) .
- (2) Construct the bisector of the angle between $\frac{CT}{CT'}$ and AB to intersect the ray $\frac{K_P T}{K_P T'}$ at K_Q .

Then, K_Q and $K_{Q'}$ are the centers of the two neighbors of (K_P) . AB , and to the arc AB containing K_P .

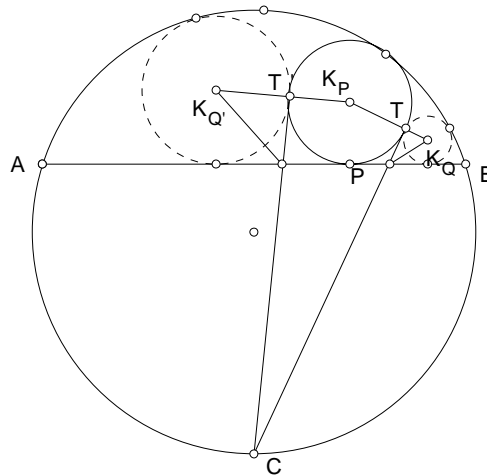

Exercise

- Let C be the midpoint of the major arc AB . If two neighbor circles (K_P) and (K_Q) are congruent, then they touch each other at a point T on the diameter CM such that $CT = CA$.

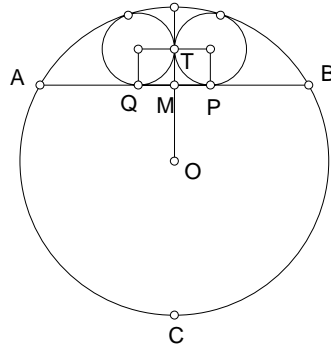

- The curvilinear triangle is bounded by two circular arcs $A(B)$ and $B(A)$, and a common radius AB . CD is parallel to AB , and is at a distance b . Denote the length of AB by a . Calculate the radius of the inscribed circle.

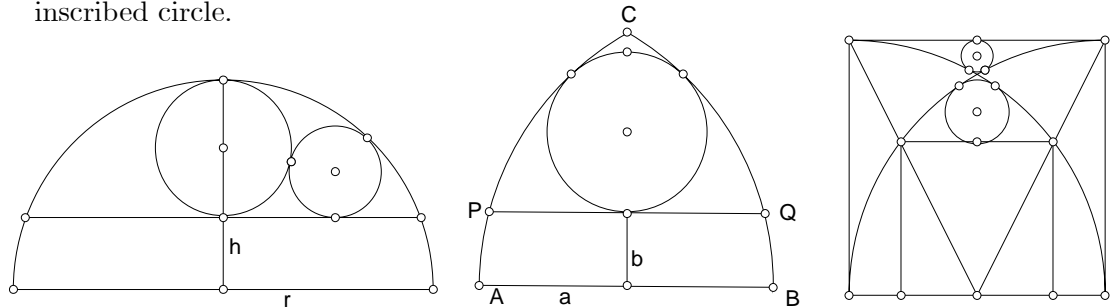

- If each side of the square has length a , calculate the radii of the two small circles.
- Given a chord AB of a circle (O) which is not a diameter, locate the points P on AB such that the radius of (K'_P) is equal to $\frac{1}{2}(R - h)$.⁴

⁴Answer: $x = \pm \sqrt{2h(R - h)}$.

5. $A(B)$ and $B(A)$

To construct the two circles tangent to the minor arc, the chord AB , and the circle (K_P) , we proceed as follows.

(1) Let C be the midpoint of the major arc AB . Complete the rectangle $BMCD$, and mark on the line AB points A', B' such that $A'M = MB' = MD$.

(2) Let the perpendicular to AB through P intersect the circle (O) at P_1 and P_2 .

(3) Let the circle passing through P_1, P_2 , and A' intersect the chord AB at Q .

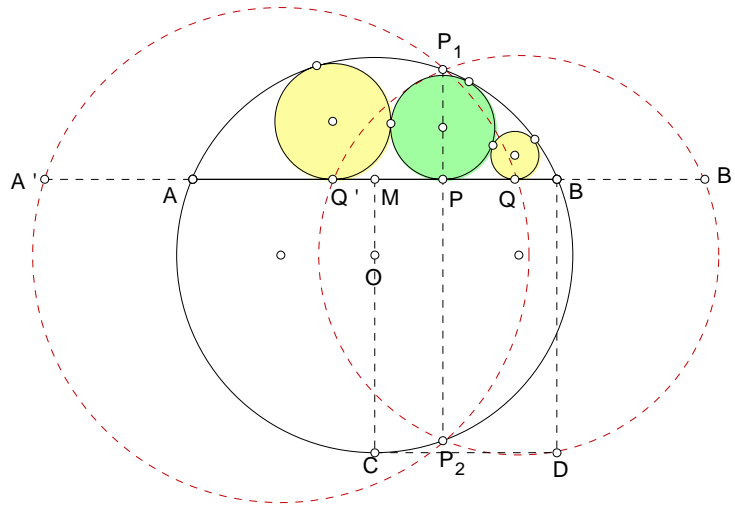

Then the circles tangent to the minor arc and to the chord AB at Q and Q' are also tangent to the circle (K_P) .

Proof. Let (K_P) and (K_Q) be two circles each tangent to the minor arc and the chord AB , and are tangent to each other externally. If their points of contact have coordinates x and y on AB (with midpoint M as origin), then

$$(x - y)^2 = 4r_P r_Q = \frac{(R^2 - h^2 - x^2)(R^2 - h^2 - y^2)}{(R + h)^2}.$$

Solving this equation for y in terms of x , we have

$$y - x = \frac{R^2 - h^2 - x^2}{\sqrt{2R^2 + 2Rh \pm x}}.$$

Now, $R^2 - h^2 - x^2 = AM^2 - MP^2 = AP \cdot PB = P_1P \cdot PP_2$, and $2R^2 + 2Rh = (R + h)^2 + (R^2 - h^2) = MC^2 + MB^2 = MD^2$. This justifies the above construction.

4.4 Mixtilinear incircles

L.Bankoff⁶ has coined the term mixtilinear incircle of a triangle for a circle tangent to two sides and the circumcircle internally. Let $K(\rho)$ be the circle tangent to the sides AB , AC , and the circumcircle at X_3 , X_2 , and A' respectively. If E is the midpoint of AC , then $KX_2 = \rho$ and $OE = R \cos \beta$. Also, $AX_2 = \rho \cot \alpha$

$$\begin{aligned}
&= 4R \frac{\sin \frac{\alpha}{2} \sin \frac{\beta}{2}}{\cos^2 \frac{\alpha}{2}} \left[\cos \frac{\alpha}{2} \cos \frac{\beta}{2} - \sin \frac{\alpha}{2} \sin \frac{\beta}{2} \right] \\
&= 4R \frac{\sin \frac{\alpha}{2} \sin \frac{\beta}{2}}{\cos^2 \frac{\alpha}{2}} \cos \frac{\alpha + \beta}{2} \\
&= 4R \frac{\sin \frac{\alpha}{2} \sin \frac{\beta}{2} \sin \frac{\gamma}{2}}{\cos^2 \frac{\alpha}{2}} \\
&= \frac{r}{\cos^2 \frac{\alpha}{2}}.
\end{aligned}$$

We summarize this with a slight change of notation.

4.4.1

The radius of the mixtilinear incircle in the angle A is given by

$$\rho_1 = r \cdot \sec^2 \frac{\alpha}{2}.$$

This formula enables one to locate the mixtilinear incenter K_1 very easily. Note that the segment X_2X_3 contains the incenter I as its midpoint, and the mixtilinear incenter K_1 is the intersection of the perpendiculars to AB and AC at X_3 and X_2 respectively.

Exercise

1. In each of the following cases, the largest circle is the circumcircle of the triangle (respectively equilateral and right). The smallest circle is the incircle of the triangle, and the other circle touches two sides of the triangle and the circumcircle. Compute the ratio of the radii of the two smaller circles.

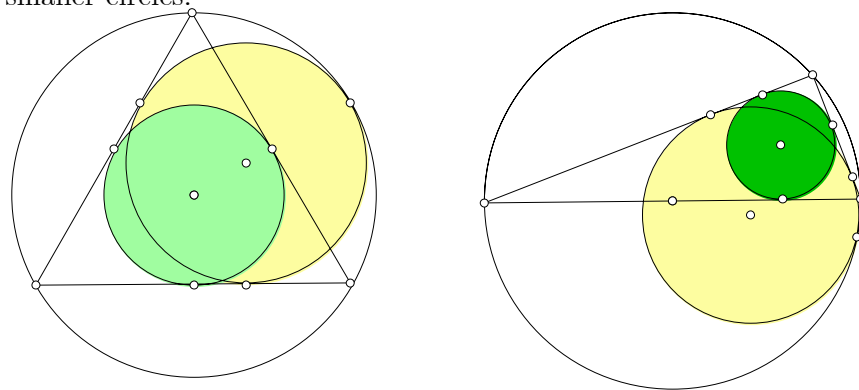

2. ABC is a right triangle for which the mixtilinear incircle (K) of the right angle touches the circumcircle at a point P such that KP is parallel to a leg of the triangle. Find the ratio of the sides of the triangle.⁷

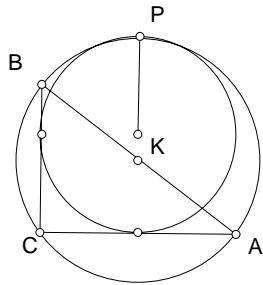

3. ABC is an isosceles triangle with $AB = AC = 2$ and $BC = 3$. Show that the $\rho_1 = 2\rho_2$.
4. ABC is an isosceles triangle with $AB = AC$. If $\rho_1 = k\rho_2$, show that $k < 2$, and the sides are in the ratio $1 : 1 : 2 - k$.⁸
5. The large circle has radius R . The three small circles have equal radii. Find this common radius.⁹

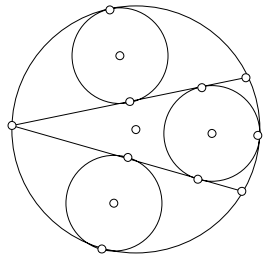

4.4.2

Consider also the mixtilinear incircles in the angles B and C . Suppose the mixtilinear incircle in angle B touch the sides BC and AB at the points Y_1

⁷3:4:5.

⁸If $\rho_2 = k\rho_1$, then $\tan \frac{\beta}{2} = \sqrt{\frac{k}{4-k}}$, so that $\cos \beta = \frac{1 - \frac{k}{4-k}}{1 + \frac{k}{4-k}} = \frac{2-k}{2}$.

⁹Answer: $\frac{3-\sqrt{5}}{2}R$.

and Y_3 respectively, and that in angle C touch the sides BC and AC at Z_1 and Z_2 respectively.

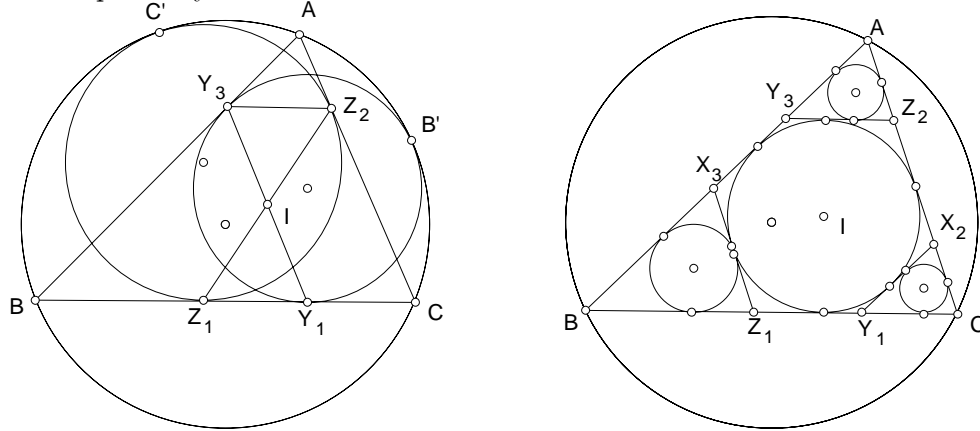

Each of the segments X_2X_3 , Y_3Y_1 , and Z_1Z_2 has the incenter I as midpoint. It follows that the triangles IY_1Z_1 and IY_3Z_2 are congruent, and the segment Y_3Z_2 is parallel to the side BC containing the segment Y_1Z_1 , and is tangent to the incircle. Therefore, the triangles AY_3Z_2 and ABC are similar, the ratio of similarity being

$$\frac{Y_3Z_2}{a} = \frac{h_a - 2r}{h_a},$$

with $h_a = \frac{2\Delta}{a} = \frac{2rs}{a}$, the altitude of triangle ABC on the side BC . Simplifying this, we obtain $\frac{Y_3Z_2}{a} = \frac{s-a}{s}$. From this, the inradius of the triangle AY_3Z_2 is given by $r_a = \frac{s-a}{s} \cdot r$. Similarly, the inradii of the triangles BZ_1X_3 and CX_2BY_1 are $r_b = \frac{s-b}{s} \cdot r$ and $r_c = \frac{s-c}{s} \cdot r$ respectively. From this, we have

$$r_a + r_b + r_c = r.$$

We summarize this in the following proposition.

Proposition

If tangents to the incircles of a triangle are drawn parallel to the sides, cutting out three triangles each similar to the given one, the sum of the inradii of the three triangles is equal to the inradius of the given triangle.

4.5 Mixtilinear excircles

The mixtilinear excircles are analogously defined. The mixtilinear exradius in the angle A is given by

$$\rho_A = r_a \sec^2 \frac{\alpha}{2},$$

where $r_a = \frac{\Delta}{s-a}$ is the corresponding exradius.

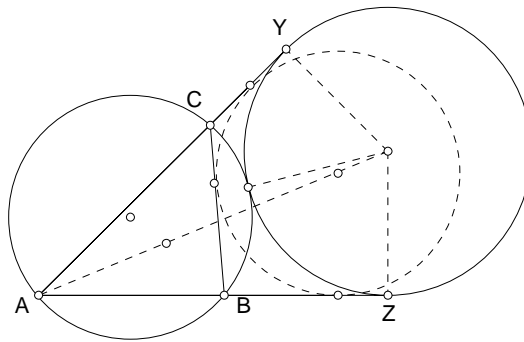

Chapter 5

The shoemaker's knife

5.1 The shoemaker's knife

Let P be a point on a segment AB . The region bounded by the three semicircles (on the same side of AB) with diameters AB , AP and PB is called a shoemaker's knife. Suppose the smaller semicircles have radii a and b respectively. Let Q be the intersection of the largest semicircle with the perpendicular through P to AB . This perpendicular is an internal common tangent of the smaller semicircles.

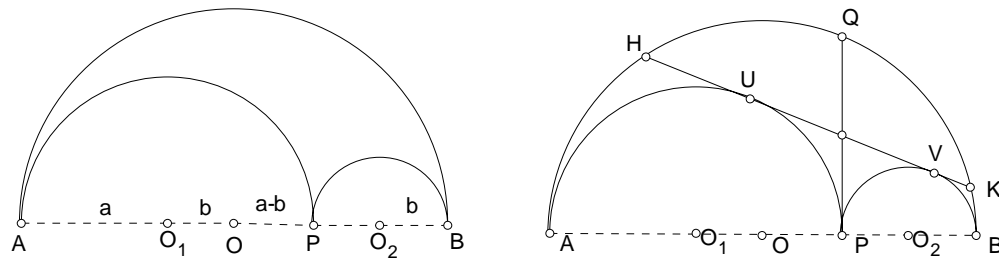

Exercise

1. Show that the area of the shoemaker's knife is πab .
2. Let UV be the external common tangent of the smaller semicircles. Show that $UPQV$ is a rectangle.
3. Show that the circle through U , P , Q , V has the same area as the shoemaker's knife.

5.1.1 Archimedes' Theorem

The two circles each tangent to CP , the largest semicircle AB and one of the smaller semicircles have equal radii t , given by

$$t = \frac{ab}{a+b}.$$

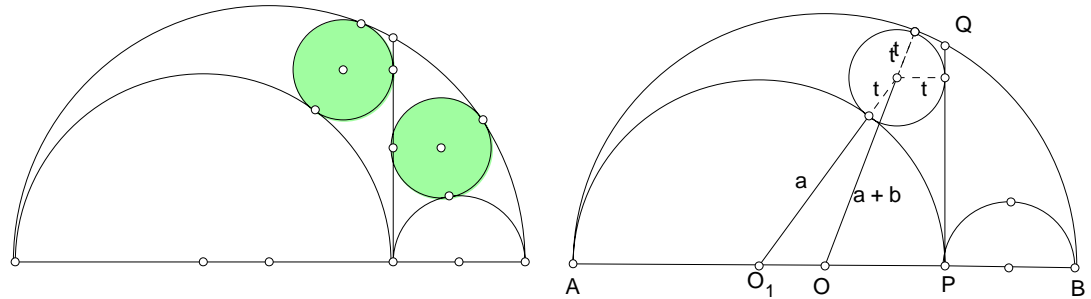

Proof. Consider the circle tangent to the semicircles $O(a+b)$, $O_1(a)$, and the line PQ . Denote by t the radius of this circle. Calculating in two ways the height of the center of this circle above the line AB , we have

$$(a+b-t)^2 - (a-b-t)^2 = (a+t)^2 - (a-t)^2.$$

From this,

$$t = \frac{ab}{a+b}.$$

The symmetry of this expression in a and b means that the circle tangent to $O(a+b)$, $O_2(b)$, and PQ has the same radius t . This proves the theorem.

5.1.2 Construction of the Archimedean circles

Let Q_1 and Q_2 be points on the semicircles $O_1(a)$ and $O_2(b)$ respectively such that O_1Q_1 and O_2Q_2 are perpendicular to AB . The lines O_1Q_2 and O_2Q_1 intersect at a point C_3 on PQ , and

$$C_3P = \frac{ab}{a+b}.$$

Note that $C_3P = t$, the radius of the Archimedean circles. Let M_1 and M_2 be points on AB such that $PM_1 = PM_2 = C_3P$. The center C_1 of the

Archimedean circle $C_1(t)$ is the intersection of the circle $O_1(M_2)$ and the perpendicular through M_1 to AB . Likewise, C_2 is the intersection of the circle $O_2(M_1)$ and the perpendicular through M_2 to AB .

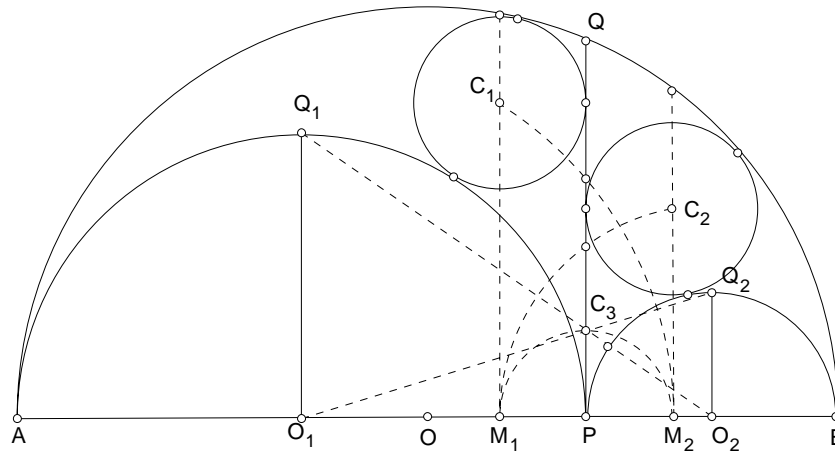

5.1.3 Incircle of the shoemaker's knife

The circle tangent to each of the three semicircles has radius given by

$$\rho = \frac{ab(a+b)}{a^2+ab+b^2}.$$

Proof. Let $\angle COO_2 = \theta$. By the cosine formula, we have

$$\begin{aligned} (a+\rho)^2 &= (a+b-\rho)^2 + b^2 + 2b(a+b-\rho)\cos\theta, \\ (b+\rho)^2 &= (a+b-\rho)^2 + a^2 - 2a(a+b-\rho)\cos\theta. \end{aligned}$$

Eliminating ρ , we have

$$a(a+\rho)^2 + b(b+\rho)^2 = (a+b)(a+b-\rho)^2 + ab^2 + ba^2.$$

The coefficients of ρ^2 on both sides are clearly the same. This is a linear equation in ρ :

$$a^3 + b^3 + 2(a^2 + b^2)\rho = (a+b)^3 + ab(a+b) - 2(a+b)^2\rho,$$

from which

$$4(a^2 + ab + b^2)\rho = (a + b)^3 + ab(a + b) - (a^3 + b^3) = 4ab(a + b),$$

and ρ is as above.

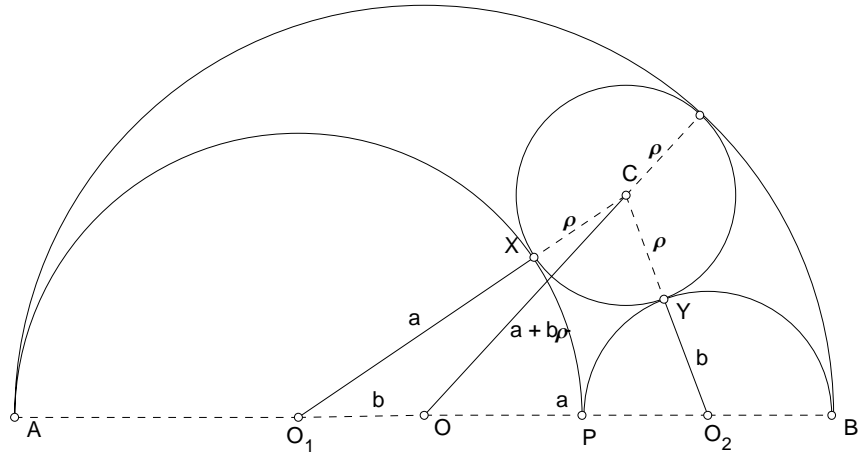

5.1.4 Bankoff's Theorem

If the incircle $C(\rho)$ of the shoemaker's knife touches the smaller semicircles at X and Y , then the circle through the points P, X, Y has the same radius as the Archimedean circles.

Proof. The circle through P, X, Y is clearly the incircle of the triangle CO_1O_2 , since

$$CX = CY = \rho, \quad O_1X = O_1P = a, \quad O_2Y = O_2P = b.$$

The semiperimeter of the triangle CO_1O_2 is

$$a + b + \rho = (a + b) + \frac{ab(a + b)}{a^2 + ab + b^2} = \frac{(a + b)^3}{a^2 + ab + b^2}.$$

The inradius of the triangle is given by

$$\sqrt{\frac{ab\rho}{a + b + \rho}} = \sqrt{\frac{ab \cdot ab(a + b)}{(a + b)^3}} = \frac{ab}{a + b}.$$

This is the same as t , the radius of the Archimedean circles.

5.1.5 Construction of incircle of shoemaker’s knife

Locate the point C_3 as in §???. Construct circle $C_3(P)$ to intersect $O_1(a)$ and $O_2(b)$ at X and Y respectively. Let the lines O_1X and O_2Y intersect at C . Then $C(X)$ is the incircle of the shoemaker’s knife.

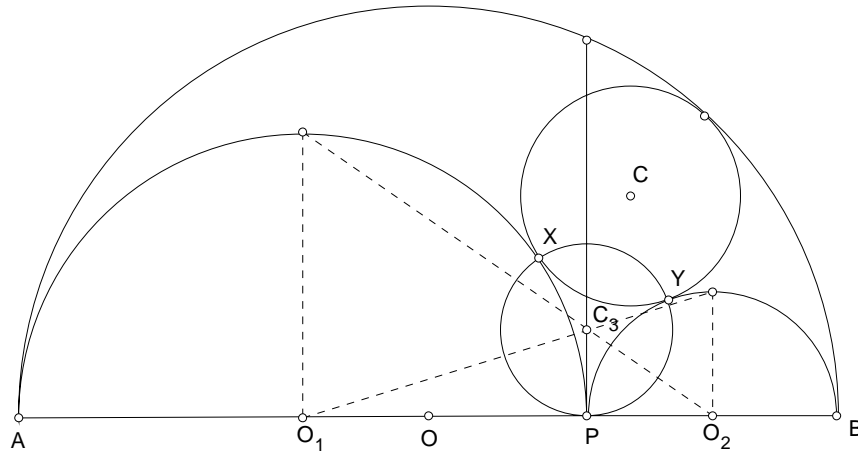

Note that $C_3(P)$ is the Bankoff circle, which has the same radius as the Archimedean circles.

Exercise

1. Show that the area of triangle CO_1O_2 is

$$\frac{ab(a + b)^2}{a^2 + ab + b^2}.$$

2. Show that the center C of the incircle of the shoemaker’s knife is at a distance 2ρ from the line AB .
3. Show that the area of the shoemaker’s knife to that of the heart (bounded by semicircles $O_1(a)$, $O_2(b)$ and the lower semicircle $O(a+b)$) is as ρ to $a + b$.

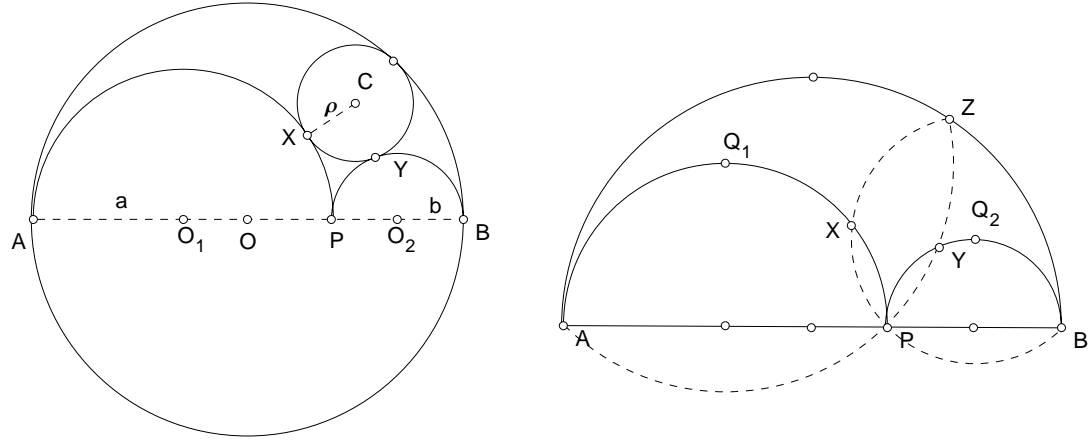

4. Show that the points of contact of the incircle $C(\rho)$ with the semicircles can be located as follows: Y, Z are the intersections with $Q_1(A)$, and X, Z are the intersections with $Q_2(B)$.
5. Show that PZ bisects angle AZB .

5.2 Archimedean circles in the shoemaker's knife

Let $t = \frac{ab}{a+b}$ as before.

5.2.1

Let UV be the external common tangent of the semicircles $O_1(a)$ and $O_2(b)$, which extends to a chord HK of the semicircle $O(a+b)$.

Let C_4 be the intersection of O_1V and O_2U . Since

$$O_1U = a, \quad O_2V = b, \quad \text{and} \quad O_1P : PO_2 = a : b,$$

$C_4P = \frac{ab}{a+b} = t$. This means that the circle $C_4(t)$ passes through P and touches the common tangent HK of the semicircles at N .

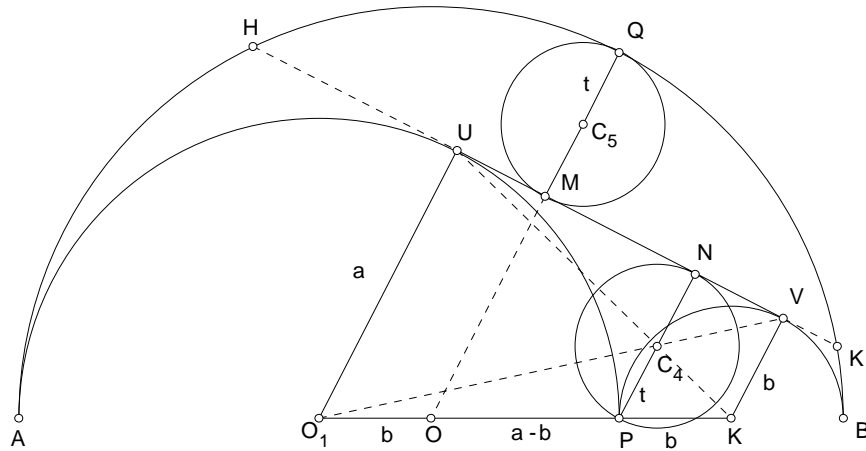

Let M be the midpoint of the chord HK . Since O and P are symmetric (isotomic conjugates) with respect to O_1O_2 ,

$$OM + PN = O_1U + O_2V = a + b.$$

it follows that $(a + b) - QM = PN = 2t$. From this, the circle tangent to HK and the minor arc HK of $O(a + b)$ has radius t . This circle touches the minor arc at the point Q .

5.2.2

Let OI' , O_1Q_1 , and O_2Q_2 be radii of the respective semicircles perpendicular to AB . Let the perpendiculars to AB through O and P intersect Q_1Q_2 at I and J respectively. Then $PJ = 2t$, and since O and P are isotomic conjugates with respect to O_1O_2 ,

$$OI = (a + b) - 2t.$$

It follows that $II' = 2t$. Note that $OQ_1 = OQ_2$. Since I and J are isotomic conjugates with respect to Q_1Q_2 , we have $JJ' = II' = 2t$.

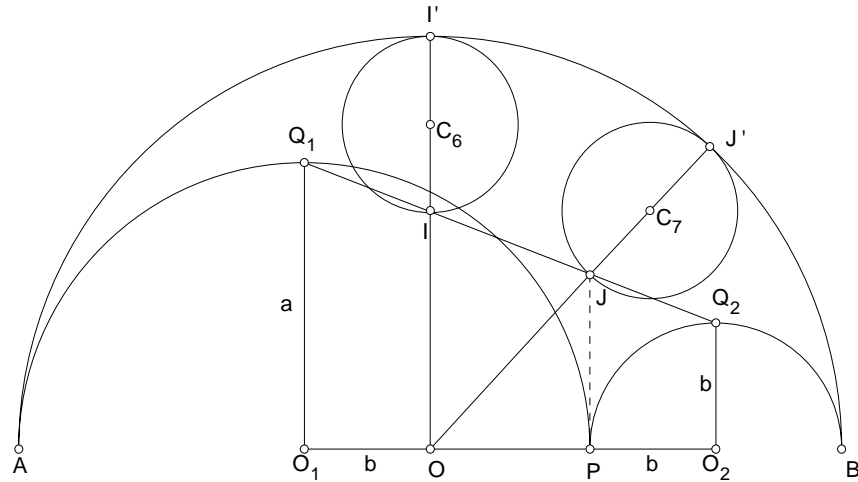

It follows that each of the circles through I and J tangent to the minor arc of $O(a + b)$ has the same radius t .¹

5.2.3

The circles $C_1(t)$ and $M_2(t)$ have two internal common tangents, one of which is the line PQ . The second internal common tangent passes through the point $\frac{B}{A}$.²

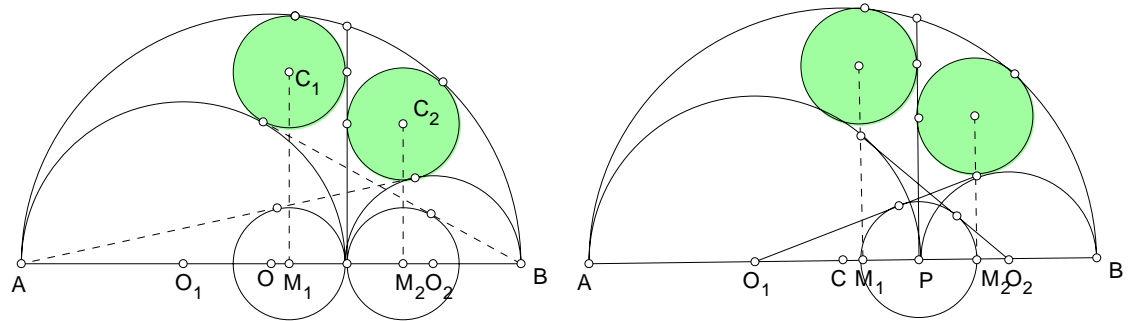

¹These circles are discovered by Thomas Schoch of Essen, Germany.

²Dodge, in In Eves' Circle.

5.2.4

The external common tangent of $P(t)$ and $O_1(a)$ passes through O_2 .

5.3 The Schoch line

5.3.1

The incircle of the curvilinear triangle bounded by the semicircle $O(a+b)$ and the circles $A(2a)$ and $B(2b)$ has radius $t = \frac{ab}{a+b}$.

Proof. Denote this circle by $S(x)$. Note that SO is a median of the triangle SO_1O_2 . By Apollonius theorem,

$$(2a + x)^2 + (2b + x)^2 = 2[(a + b)^2 + (a + b - x)^2].$$

From this,

$$x = \frac{ab}{a + b} = t.$$

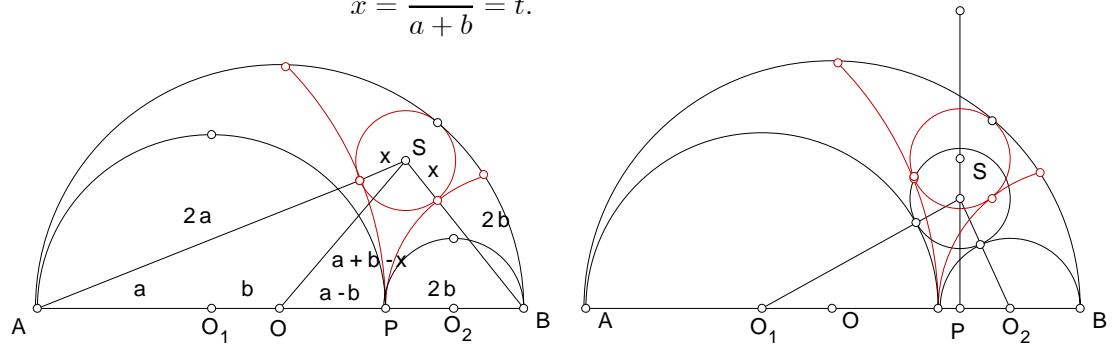

5.3.2 Theorem (Schoch)

If a circle of radius $t = \frac{ab}{a+b}$ is tangent externally to each of the semicircles $O_1(a)$ and $O_2(b)$, its center lies on the perpendicular to AB through S .

5.3.3 Theorem (Woo)

For $k > 0$, consider the circular arcs through P , centers on the line AB (and on opposite sides of P), radii kr_1 , kr_2 respectively. If a circle of radius $t = \frac{ab}{a+b}$ is tangent externally to both of them, then its center lies on the Schoch line, the perpendicular to AB through S .

circles tangent externally at P , and
 ch of these. The distance from the
 P is, by the cosine formula

$$\frac{(kb + t)^2}{a + b} - ka$$

$$+ \frac{k^2(a + b)^2 - 2k^2a(a + b)}{a + b}$$

ding proposition. It happens to be

he semicircle $O(a + b)$ touches the

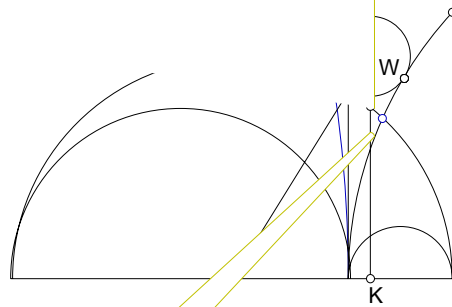

and

$$QW = \underline{OQ}$$

3. S'' is the point S_k for $k = \frac{3}{4}$.
4. S' is $\sqrt{(2a+x)(2b-x)}$ above AB , and

$$MS' = \frac{a^2 + 6ab + b^2}{2(a+b)}.$$

From this, deduce that $TS' = 2t$.

5. S' is the point S_k for $k = \frac{2a^2 + 11ab + 2b^2}{4ab}$.
6. $PTS'S''$ is a parallelogram.

Chapter 6

The Use of Complex Numbers

6.1 Review on complex numbers

A complex number $z = x + yi$ has a real part x and an imaginary part y . The conjugate of z is the complex number $\bar{z} = x - yi$. The norm is the nonnegative number $|z|$ given by $|z|^2 = x^2 + y^2$. Note that

$$|z|^2 = z\bar{z} = \bar{z}z.$$

z is called a unit complex number if $|z| = 1$. Note that $|z| = 1$ if and only if $\bar{z} = \frac{1}{z}$.

Identifying the complex number $z = x + yi$ with the point (x, y) in the plane, we note that $|z_1 - z_2|$ measures the distance between z_1 and z_2 . In particular, $|z|$ is the distance between $|z|$ and the origin 0 . Note also that \bar{z} is the mirror image of z in the horizontal axis.

6.1.1 Multiplicative property of norm

For any complex numbers z_1 and z_2 , $|z_1 z_2| = |z_1| |z_2|$.

6.1.2 Polar form

Each complex number z can be expressed in the form $z = |z|(\cos \theta + i \sin \theta)$, where θ is unique up to a multiple of 2π , and is called the argument of z .

6.1.3 De Moivre Theorem

$$(\cos \theta_1 + i \sin \theta_1)(\cos \theta_2 + i \sin \theta_2) = \cos(\theta_1 + \theta_2) + i \sin(\theta_1 + \theta_2).$$

In particular,

$$(\cos \theta + i \sin \theta)^n = \cos n\theta + i \sin n\theta.$$

6.2 Coordinatization

Given $\triangle ABC$, we set up a coordinate system such that the circumcenter O corresponds to the complex number 0, and the vertices A, B, C correspond to unit complex numbers z_1, z_2, z_3 respectively. In this way, the circumradius R is equal to 1.

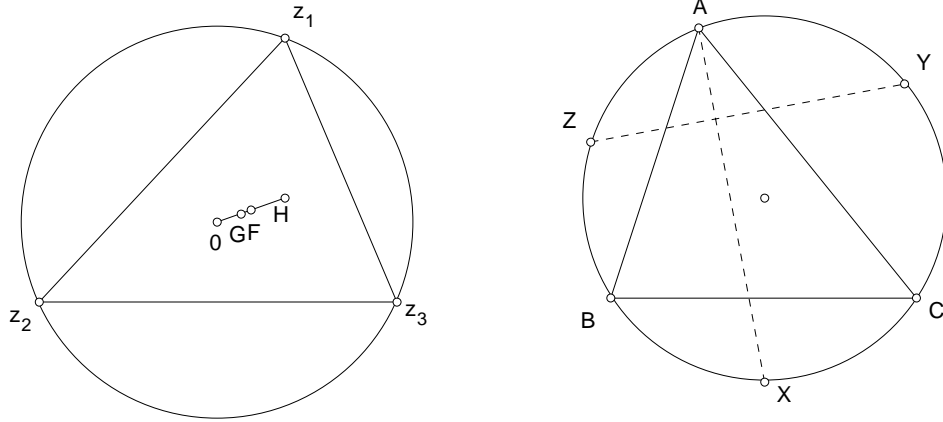

Exercise

1. The centroid G has coordinates $\frac{1}{3}(z_1 + z_2 + z_3)$.
2. The orthocenter H has coordinates $z_1 + z_2 + z_3$.
3. The nine-point center F has coordinates $\frac{1}{2}(z_1 + z_2 + z_3)$.
4. Let X, Y, Z be the midpoints of the minor arcs BC, CA, AB of the circumcircle of $\triangle ABC$ respectively. Prove that AX is perpendicular to YZ . [Hint: Consider the tangents at Y and Z . Show that these are parallel to AC and AB respectively.] Deduce that the orthocenter of $\triangle XYZ$ is the incenter I of $\triangle ABC$.

6.2.1 The incenter

Now, we try to identify the coordinate of the incenter I . This, according to the preceding exercise, is the orthocenter of $\triangle XYZ$.

It is possible to choose unit complex numbers t_1, t_2, t_3 such that

$$z_1 = t_1^2, \quad z_2 = t_2^2, \quad z_3 = t_3^2,$$

and X, Y, Z are respectively the points $-t_2t_3, -t_3t_1$ and $-t_1t_2$. From these, the incenter I , being the orthocenter of $\triangle XYZ$, is the point $-(t_2t_3 + t_3t_1 + t_1t_2) = -t_1t_2t_3(\overline{t_1 + t_2 + t_3})$.

Exercise

1. Show that the excenters are the points

$$\begin{aligned} I_A &= t_1t_2t_3(\overline{-t_1 + t_2 + t_3}), \\ I_B &= t_1t_2t_3(\overline{t_1 - t_2 + t_3}), \\ I_C &= t_1t_2t_3(\overline{t_1 + t_2 - t_3}). \end{aligned}$$

6.3 The Feuerbach Theorem

The nine-point circle of a triangle is tangent internally to the incircle, and externally to each of the excircles.

Proof. Note that the distance between the incenter I and the nine-point center F is

$$\begin{aligned} IF &= \left| \frac{1}{2}(t_1^2 + t_2^2 + t_3^2) + (t_1t_2 + t_2t_3 + t_3t_1) \right| \\ &= \left| \frac{1}{2}(t_1 + t_2 + t_3)^2 \right| \\ &= \frac{1}{2}|t_1 + t_2 + t_3|^2. \end{aligned}$$

Since the circumradius $R = 1$, the radius of the nine-point circle is $\frac{1}{2}$. We apply Theorem 3.5.1 to calculate the inradius r :

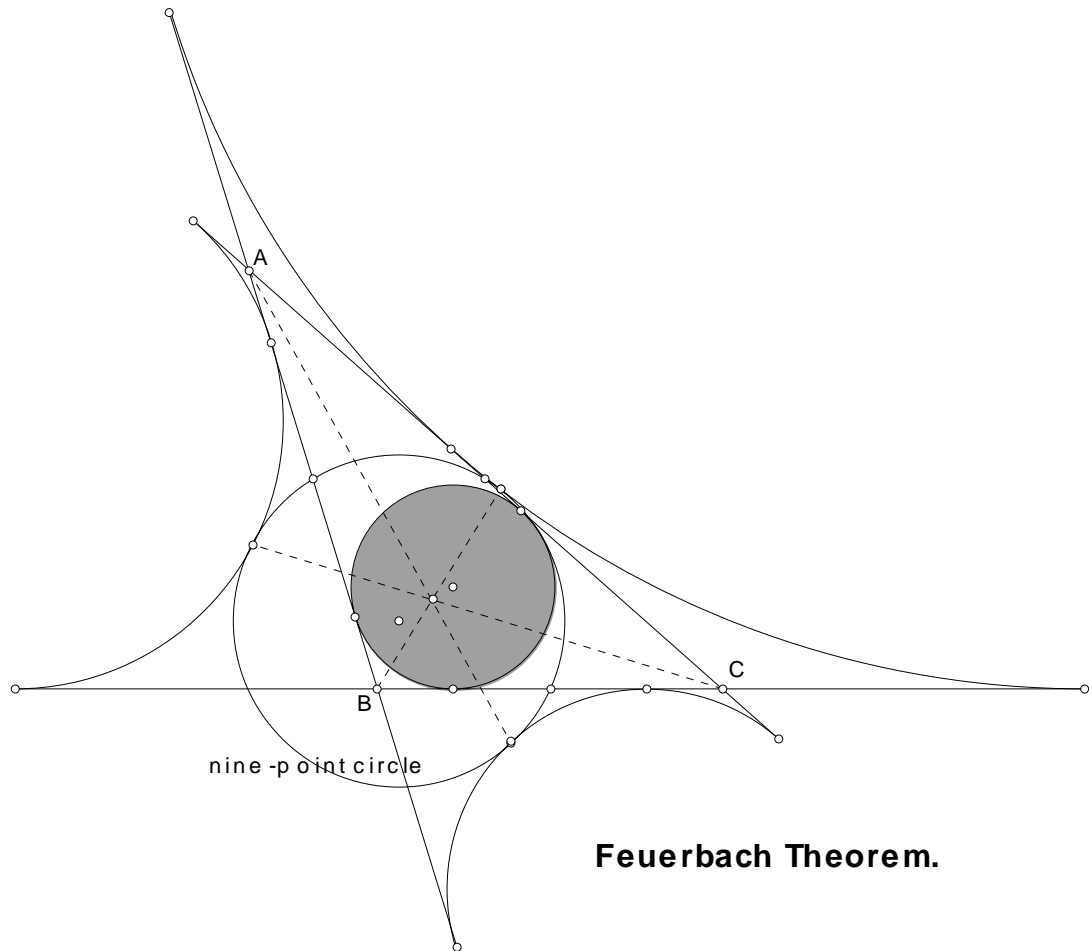

$$\begin{aligned}
 r &= \frac{1}{2}(1 - OI^2) \\
 &= \frac{1}{2}(1 - |-t_1 t_2 t_3 \overline{(t_1 + t_2 + t_3)}|^2) \\
 &= \frac{1}{2}(1 - |t_1 + t_2 + t_3|^2) \\
 &= \frac{1}{2} - IF.
 \end{aligned}$$

This means that IF is equal to the difference between the radii of the nine-point circle and the incircle. These two circles are therefore tangent internally.

Exercise

Complete the proof of the Feuerbach theorem.

1. $I_A F = \frac{1}{2} | -t_1 + t_2 + t_3 |^2$.
2. If d_A is the distance from O to I_A , then $d_A = | -t_1 + t_2 + t_3 |$.
3. The exradius $r_A = I_A F - \frac{1}{2}$.

6.3.1 The Feuerbach point

Indeed, the three lines each joining the point of contact of the nine-point with an excircle to the opposite vertex of the triangle are concurrent.

Exercise

1. Let D be the midpoint of the side BC of triangle ABC . Show that one of the common tangents of the circles $I(N)$ and $D(N)$ is parallel to BC .

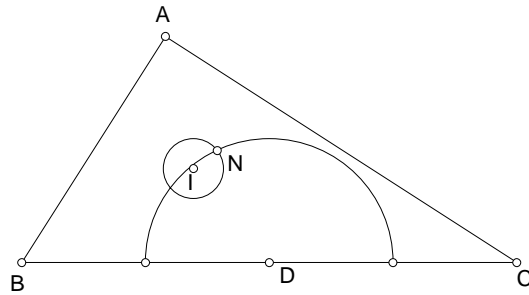

2. The nine-point circle is tangent to the circumcircle if and only if the triangle is right.
3. More generally, the nine-point circle intersects the circumcircle only if one of $\alpha, \beta, \gamma \geq \frac{\pi}{2}$. In that case, they intersect at an angle $\arccos(1 + 2 \cos \alpha \cos \beta \cos \gamma)$.

6.4

The shape and orientation of a triangle with vertices z_1, z_2, z_3 is determined by the ratio

$$\frac{z_3 - z_1}{z_2 - z_1}.$$

6.4.1

Two triangles with vertices (z_1, z_2, z_3) and (w_1, w_2, w_3) are similar with the same orientation if and only if

$$\frac{z_3 - z_1}{z_2 - z_1} = \frac{w_3 - w_1}{w_2 - w_1}.$$

Equivalently,

$$\det \begin{pmatrix} z_1 & w_1 & 1 \\ z_2 & w_2 & 1 \\ z_3 & w_3 & 1 \end{pmatrix} = 0.$$

Exercise

1. Three distinct points z_1, z_2, z_3 are collinear if and only if $\frac{z_3 - z_1}{z_2 - z_1}$ is a real number.
2. Three distinct points z_1, z_2, z_3 are collinear if and only if

$$\det \begin{pmatrix} z_1 & \bar{z}_1 & 1 \\ z_2 & \bar{z}_2 & 1 \\ z_3 & \bar{z}_3 & 1 \end{pmatrix} = 0.$$

3. The equation of the line joining two distinct points z_1 and z_2 is

$$\bar{z} = Az + B,$$

where

$$A = \frac{\bar{z}_1 - \bar{z}_2}{z_1 - z_2}, \quad B = \frac{z_1 \bar{z}_2 - z_2 \bar{z}_1}{z_1 - z_2}.$$

4. Show that if $\bar{z} = Az + B$ represents a line of slope λ , then A is a unit complex number, and $\lambda = -\frac{1-A}{1+A}i$.
5. The mirror image of a point z in the line $\bar{z} = Az + B$ is the point $\overline{Az + B}$.

6.4.2

Let ω denote a complex cube root of unity:

$$\omega = \frac{1}{2}(-1 + \sqrt{3}i).$$

This is a root of the quadratic equation $x^2 + x + 1 = 0$, the other root being

$$\omega^2 = \bar{\omega} = \frac{1}{2}(-1 - \sqrt{3}i).$$

Note that $1, \omega, \omega^2$ are the vertices of an equilateral triangle (with counter-clockwise orientation).

6.4.3

z_1, z_2, z_3 are the vertices of an equilateral triangle (with counter clockwise orientation) if and only if

$$z_1 + \omega z_2 + \omega^2 z_3 = 0.$$

Exercise

1. If u and v are two vertices of an equilateral triangle, find the third vertex. ¹
2. If z_1, z_2, z_3 and w_1, w_2, w_3 are the vertices of equilateral triangles (with counter clockwise orientation), then so are the midpoints of the segments z_1w_1, z_2w_2 , and z_3w_3 .
3. If z_1, z_2 are two adjacent vertices of a square, find the coordinates of the remaining two vertices, and of the center of the square.
4. On the three sides of triangle ABC , construct outward squares. Let A', B', C' be the centers of the squares on BC, CA, AB respectively, show that AA' is perpendicular to, and has the same length as $B'C'$.
5. OAB, OCD, DAX , and BCY

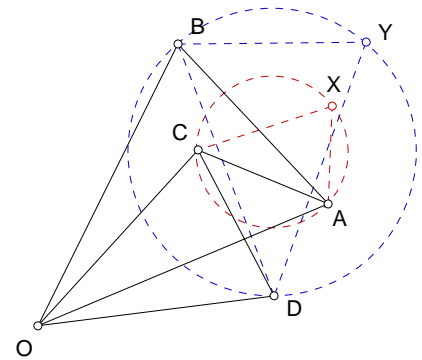
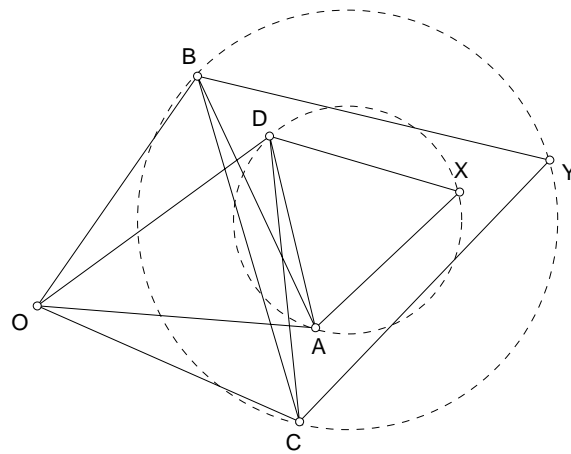

6.4.4 Napoleon's Theorem

If on each side of a given triangle, equilateral triangles are drawn, either all outside or all inside the triangle, the centers of these equilateral triangles form an equilateral triangle.

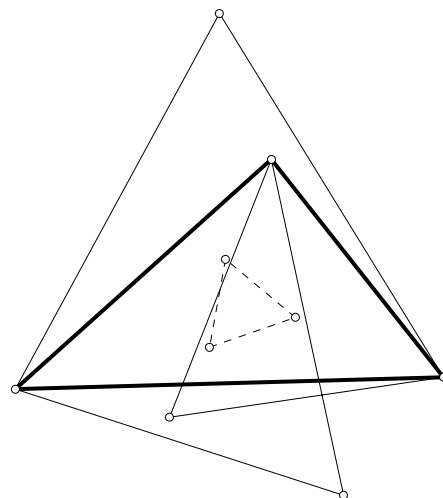
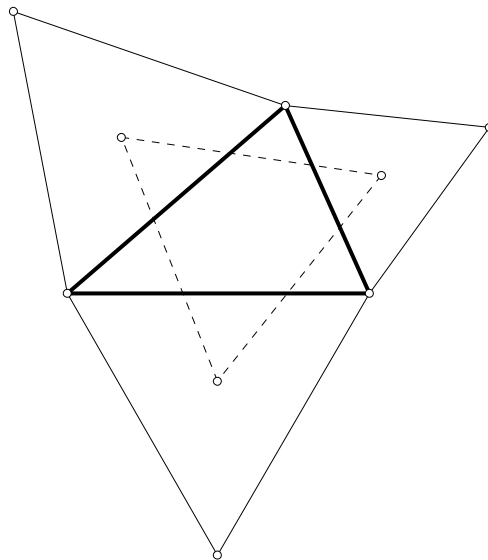

Proof. Let ω be a complex cube root of unity, so that the third vertex of an equilateral triangle on $z_1 z_2$ is $z'_3 := -(\omega z_1 + \omega^2 z_2)$. The center of this

equilateral triangle is

$$w_3 = \frac{1}{3}((1-\omega)z_1 + (1-\omega^2)z_2) = \frac{1-\omega}{3}[z_1 + (1+\omega)z_2] = \frac{1-\omega}{3}[z_1 - \omega^2 z_2].$$

Likewise, the centers of the other two similarly oriented equilateral triangles are

$$w_1 = \frac{1-\omega}{3}[z_3 - \omega^2 z_1], \quad w_2 = \frac{1-\omega}{3}[z_2 - \omega^2 z_3].$$

These form an equilateral triangle since

$$\begin{aligned} & w_1 + \omega w_2 + \omega^2 w_3 \\ &= \frac{1-\omega}{3}[z_3 + \omega z_2 + \omega^2 z_1 - \omega^2(z_1 + \omega z_3 + \omega^2 z_2)] \\ &= 0. \end{aligned}$$

Exercise

1. (Fukuta's generalization of Napoleon's Theorem)³ Given triangle ABC ,

let X_1 be points dividing the sides BC in the same ratio $1-k : k$. De-
 Z_1 AB

note by X_2 Y_2 their isotomic conjugate on the respective sides. Complete

Z_2
the following equilateral triangles, all with the same orientation,

$$X_1 X_2 X_3, Y_1 Y_2 Y_3, Z_1 Z_2 Z_3, Y_2 Z_1 X'_3, Z_2 X_1 Y'_3, X_2 Y_1 Z'_3.$$

(a) Show that the segments $X_3 X'_3$, $Y_3 Y'_3$ and $Z_3 Z'_3$ have equal lengths, 60° angles with each other, and are concurrent.

(b) Consider the hexagon $X_3 Z'_3 Y_3 X'_3 Z_3 Y'_3$. Show that the centroids of the 6 triangles formed by three consecutive vertices of this hexagon are themselves the vertices of a regular hexagon, whose center is the centroid of triangle ABC .

³Mathematics Magazine, Problem 1493.

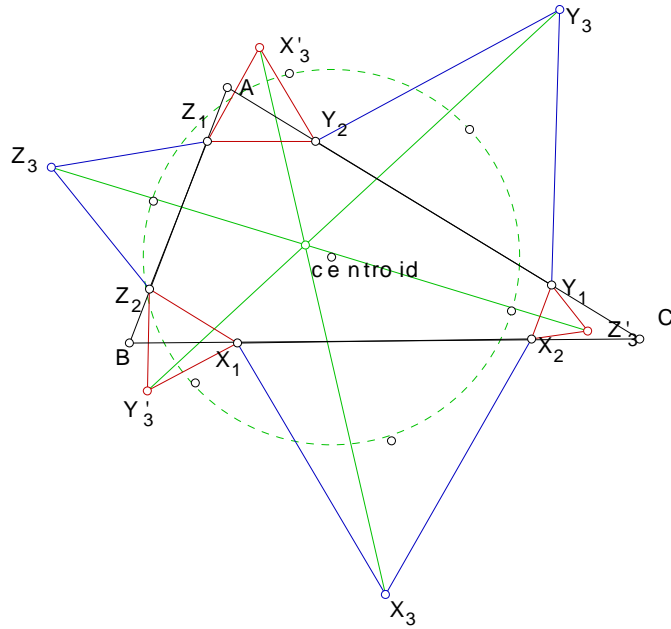

6.5 Concyclic points

Four non-collinear points z_1, z_2, z_3, z_4 are concyclic if and only if the cross ratio

$$(z_1, z_2; z_3, z_4) := \frac{z_4 - z_1}{z_3 - z_1} / \frac{z_4 - z_2}{z_3 - z_2} = \frac{(z_3 - z_2)(z_4 - z_1)}{(z_3 - z_1)(z_4 - z_2)}$$

is a real number.

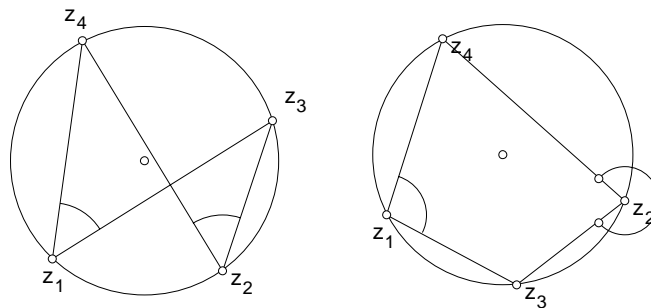

Proof. Suppose z_1 and z_2 are on the same side of z_3z_4 . The four points are concyclic if the counter clockwise angles of rotation from z_1z_3 to z_1z_4 and from z_2z_3 to z_2z_4 are equal. In this case, the ratio

$$\frac{z_4 - z_1}{z_3 - z_1} / \frac{z_4 - z_2}{z_3 - z_2}$$

of the complex numbers is real, (and indeed positive).

On the other hand, if z_1, z_2 are on opposite sides of z_3z_4 , the two angles differ by π , and the cross ratio is a negative real number.

6.6 Construction of the regular 17-gon

6.6.1 Gauss' analysis

Suppose a regular 17-gon has center $0 \in \mathbb{C}$ and one vertex represented by the complex number 1. Then the remaining 16 vertices are the roots of the equation

$$\frac{x^{17} - 1}{x - 1} = x^{16} + x^{15} + \dots + x + 1 = 0.$$

If ω is one of these 16 roots, then these 16 roots are precisely $\omega, \omega^2, \dots, \omega^{15}, \omega^{16}$. (Note that $\omega^{17} = 1$.) Geometrically, if A_0, A_1 are two distinct vertices of a regular 17-gon, then successively marking vertices A_2, A_3, \dots, A_{16} with

$$A_0A_1 = A_1A_2 = \dots = A_{14}A_{15} = A_{15}A_{16},$$

we obtain all 17 vertices. If we write $\omega = \cos \theta + i \sin \theta$, then $\omega + \omega^{16} = 2 \cos \theta$. It follows that the regular 17-gon can be constructed if one can construct the number $\omega + \omega^{16}$. Gauss observed that the 16 complex numbers $\omega^k, k = 1, 2, \dots, 16$, can be separated into two "groups" of eight, each with a sum constructible using only ruler and compass. This is decisively the hardest step. But once this is done, two more applications of the same idea eventually isolate $\omega + \omega^{16}$ as a constructible number, thereby completing the task of construction. The key idea involves the very simple fact that if the coefficients a and b of a quadratic equation $x^2 - ax + b = 0$ are constructible, then so are its roots x_1 and x_2 . Note that $x_1 + x_2 = a$ and $x_1x_2 = b$.

Gauss observed that, modulo 17, the first 16 powers of 3 form a permutation of the numbers 1, 2, \dots , 16:

k	0	1	2	3	4	5	6	7	8	9	10	11	12	13	14	15
3^k	1	3	9	10	13	5	15	11	16	14	8	7	4	12	2	6

Let

$$\begin{aligned} y_1 &= \omega + \omega^9 + \omega^{13} + \omega^{15} + \omega^{16} + \omega^8 + \omega^4 + \omega^2, \\ y_2 &= \omega^3 + \omega^{10} + \omega^5 + \omega^{11} + \omega^{14} + \omega^7 + \omega^{12} + \omega^6. \end{aligned}$$

Note that

$$y_1 + y_2 = \omega + \omega^2 + \dots + \omega^{16} = -1.$$

Most crucial, however, is the fact that the product y_1y_2 does not depend on the choice of ω . We multiply these directly, but adopt a convenient bookkeeping below. Below each power ω^k , we enter a number j (from 1 to 8 meaning that ω^k can be obtained by multiplying the j th term of y_1 by an appropriate term of y_2 (unspecified in the table but easy to determine):

ω	ω^2	ω^3	ω^4	ω^5	ω^6	ω^7	ω^8	ω^9	ω^{10}	ω^{11}	ω^{12}	ω^{13}	ω^{14}	ω^{15}	ω^{16}
3	2	2	1	4	1	1	1	4	3	1	1	1	2	1	2
4	3	3	2	5	2	3	3	5	4	5	2	5	6	2	3
6	5	4	4	6	3	7	4	7	5	6	4	6	7	6	7
7	6	6	5	8	5	8	8	8	7	7	8	8	8	7	8

From this it is clear that

$$y_1y_2 = 4(\omega + \omega^2 + \dots + \omega^{16}) = -4.$$

It follows that y_1 and y_2 are the roots of the quadratic equation

$$y^2 + y - 4 = 0,$$

and are constructible. We may take

$$y_1 = \frac{-1 + \sqrt{17}}{2}, \quad y_2 = \frac{-1 - \sqrt{17}}{2}.$$

Now separate the terms of y_1 into two “groups” of four, namely,

$$z_1 = \omega + \omega^{13} + \omega^{16} + \omega^4, \quad z_2 = \omega^9 + \omega^{15} + \omega^8 + \omega^2.$$

Clearly, $z_1 + z_2 = y_1$. Also,

$$z_1z_2 = (\omega + \omega^{13} + \omega^{16} + \omega^4)(\omega^9 + \omega^{15} + \omega^8 + \omega^2) = \omega + \omega^2 + \dots + \omega^{16} = -1.$$

It follows that z_1 and z_2 are the roots of the quadratic equation

$$z^2 - y_1z - 1 = 0,$$

and are constructible, since y_1 is constructible. Similarly, if we write

$$z_3 = \omega^3 + \omega^5 + \omega^{14} + \omega^{12}, \quad z_4 = \omega^{10} + \omega^{11} + \omega^7 + \omega^6,$$

we find that $z_3 + z_4 = y_2$, and $z_3 z_4 = \omega + \omega^2 + \cdots + \omega^{16} = -1$, so that z_3 and z_4 are the roots of the quadratic equation

$$z^2 - y_2 z - 1 = 0$$

and are also constructible.

Finally, further separating the terms of z_1 into two pairs, by putting

$$t_1 = \omega + \omega^{16}, \quad t_2 = \omega^{13} + \omega^4,$$

we obtain

$$\begin{aligned} t_1 + t_2 &= z_1, \\ t_1 t_2 &= (\omega + \omega^{16})(\omega^{13} + \omega^4) = \omega^{14} + \omega^5 + \omega^{12} + \omega^3 = z_3. \end{aligned}$$

It follows that t_1 and t_2 are the roots of the quadratic equation

$$t^2 - z_1 t + z_3 = 0,$$

and are constructible, since z_1 and z_3 are constructible.

6.6.2 Explicit construction of a regular 17-gon ⁴

To construct two vertices of the regular 17-gon inscribed in a given circle $O(A)$.

1. On the radius OB perpendicular to OA , mark a point J such that $OJ = \frac{1}{4}OA$.
2. Mark a point E on the segment OA such that $\angle OJE = \frac{1}{4}\angle OJA$.
3. Mark a point F on the diameter through A such that O is between E and F and $\angle EJF = 45^\circ$.
4. With AF as diameter, construct a circle intersecting the radius OB at K .

⁴H.S.M.Coxeter, Introduction to Geometry, 2nd ed. p.27.

5. Mark the intersections of the circle $E(K)$ with the diameter of $O(A)$ through A . Label the one between O and A points P_4 , and the other and P_6 .
6. Construct the perpendicular through P_4 and P_6 to intersect the circle $O(A)$ at A_4 and A_6 .⁵

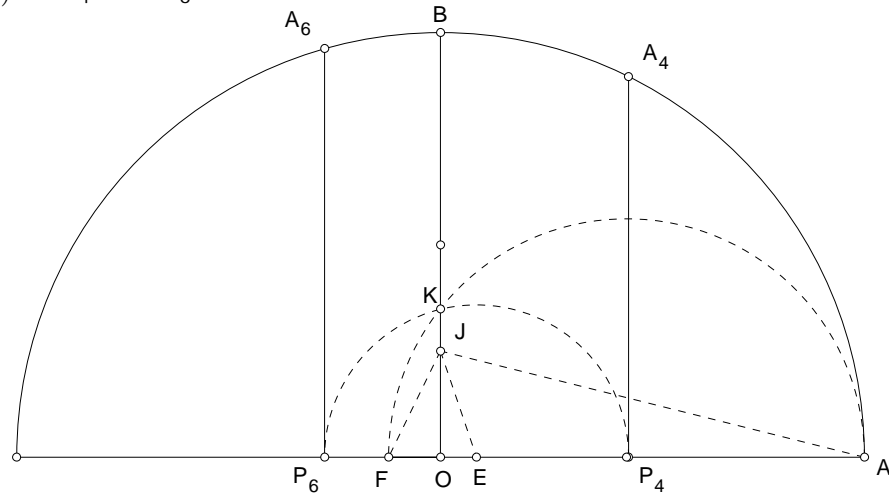

Then A_4, A_6 are two vertices of a regular 17-gon inscribed in $O(A)$. The polygon can be completed by successively laying off arcs equal to A_4A_6 , leading to $A_8, A_{10}, \dots, A_{16}, A_1 = A, A_3, A_5, \dots, A_{15}, A_{17}, A_2$.

⁵Note that P_4 is not the midpoint of AF .

Chapter 7

The Menelaus and Ceva Theorems

7.1

7.1.1 Sign convention

Let A and B be two distinct points. A point P on the line AB is said to divide the segment AB in the ratio $AP : PB$, positive if P is between A and B , and negative if P is outside the segment AB .

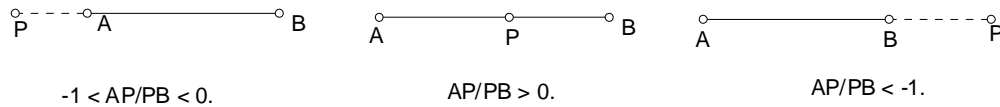

7.1.2 Harmonic conjugates

Two points P and Q on a line AB are said to divide the segment AB harmonically if they divide the segment in the same ratio, one externally and the other internally:

$$\frac{AP}{PB} = -\frac{AQ}{QB}.$$

We shall also say that P and Q are harmonic conjugates with respect to the segment AB .

7.1.3

Let P and Q be harmonic conjugates with respect to AB . If $AB = d$, $AP = p$, and $AQ = q$, then d is the harmonic mean of p and q , namely,

$$\frac{1}{p} + \frac{1}{q} = \frac{2}{d}.$$

Proof. This follows from

$$\frac{p}{d-p} = -\frac{q}{d-q}.$$

7.1.4

We shall use the abbreviation $(A, B; P, Q)$ to stand for the statement P, Q divide the segment AB harmonically.

Proposition

If $(A, B; P, Q)$, then $(A, B; Q, P)$, $(B, A; P, Q)$, and $(P, Q; A, B)$.

Therefore, we can speak of two collinear (undirected) segments dividing each other harmonically.

Exercise

1. Justify the following construction of harmonic conjugate.

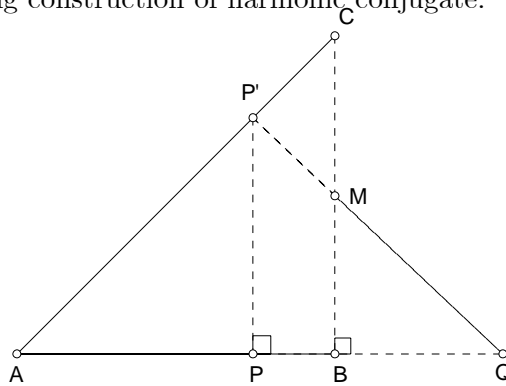

Given AB , construct a right triangle ABC with a right angle at B and $BC = AB$. Let M be the midpoint of BC .

For every point P (except the midpoint of AB), let P' be the point on AC such that $PP' \perp AB$.

The intersection Q of the lines $P'M$ and AB is the harmonic conjugate of P with respect to AB .

7.2 Apollonius Circle

7.2.1 Angle bisector Theorem

If the internal (respectively external) bisector of angle BAC intersect the line BC at X (respectively X'), then

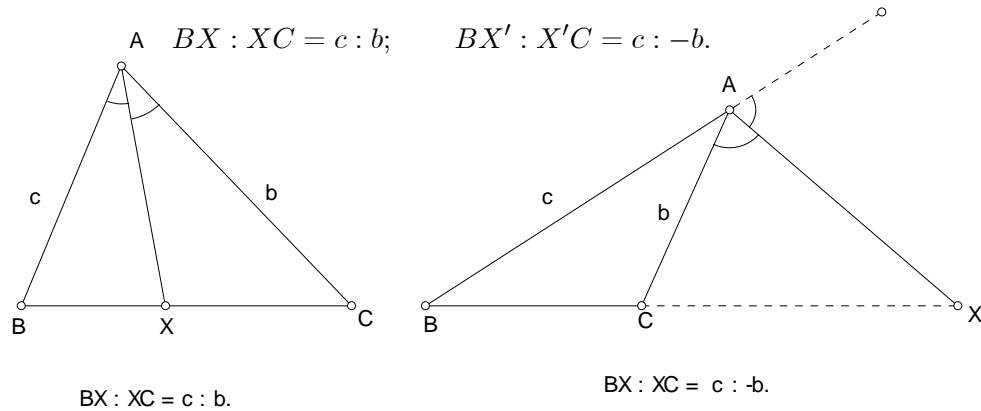

7.2.2 Example

The points X and X' are harmonic conjugates with respect to BC , since

$$BX : XC = c : b, \quad \text{and} \quad BX' : X'C = c : -b.$$

7.2.3

A and B are two fixed points. For a given positive number $k \neq 1$,¹ the locus of points P satisfying $AP : PB = k : 1$ is the circle with diameter XY , where X and Y are points on the line AB such that $AX : XB = k : 1$ and $AY : YB = k : -1$.

¹If $k = 1$, the locus is clearly the perpendicular bisector of the segment AB .

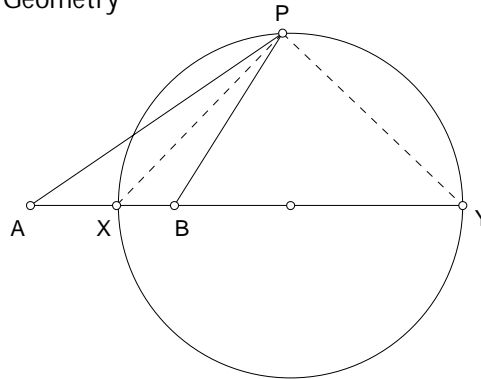

Proof. Since $k \neq 1$, points X and Y can be found on the line AB satisfying the above conditions.

Consider a point P not on the line AB with $AP : PB = k : 1$. Note that PX and PY are respectively the internal and external bisectors of angle APB . This means that angle XPY is a right angle.

Exercise

1. The bisectors of the angles intersect the sides BC , CA , AB respectively at P , Q , and R . P' , Q' , and R' on the sides CA , AB , and BC respectively such that $PP' \parallel BC$, $QQ' \parallel CA$, and $RR' \parallel AB$. Show that

$$\frac{1}{PP'} + \frac{1}{QQ'} + \frac{1}{RR'} = 2\left(\frac{1}{a} + \frac{1}{b} + \frac{1}{c}\right).$$

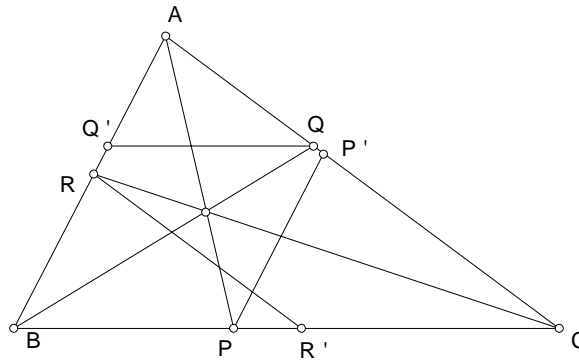

2. Suppose ABC is a triangle with $AB \neq AC$, and let D, E, F, G be points on the line BC defined as follows: D is the midpoint of BC , AE is the bisector of $\angle BAC$, F is the foot of the perpendicular from

A to BC , and AG is perpendicular to AE (i.e. AG bisects one of the exterior angles at A). Prove that $AB \cdot AC = DF \cdot EG$.

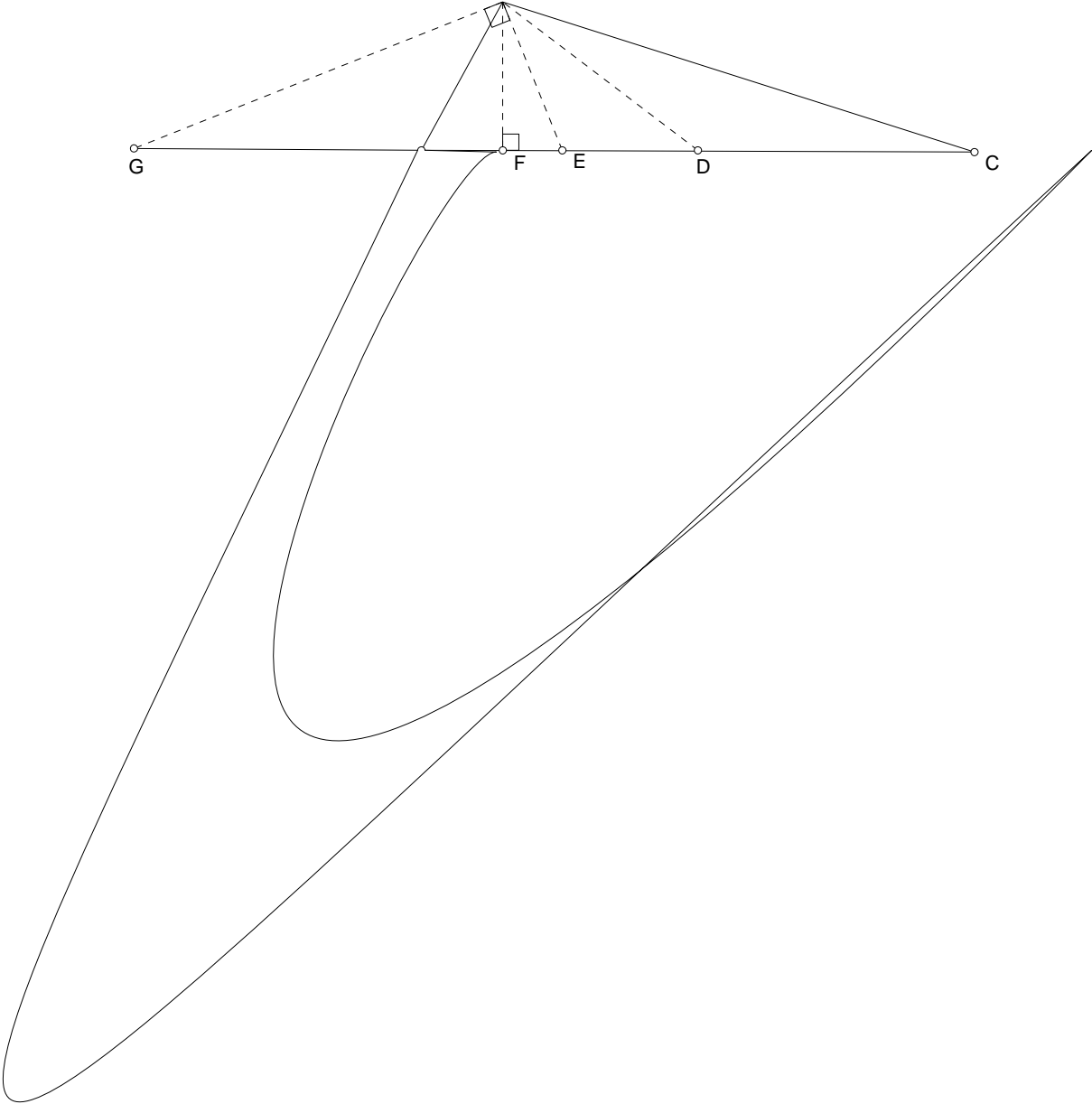

Proof. (\implies) Let W be the point on AB such that $CW \parallel XY$. Then,

$$\frac{BX}{XC} = \frac{BZ}{ZW}, \quad \text{and} \quad \frac{CY}{YA} = \frac{WZ}{ZA}.$$

It follows that

$$\frac{BX}{XC} \cdot \frac{CY}{YA} \cdot \frac{AZ}{ZB} = \frac{BZ}{ZW} \cdot \frac{WZ}{ZA} \cdot \frac{AZ}{ZB} = \frac{BZ}{ZB} \cdot \frac{WZ}{ZW} \cdot \frac{AZ}{ZA} = (-1)(-1)(-1) = -1.$$

(\impliedby) Suppose the line joining X and Z intersects AC at Y' . From above,

$$\frac{BX}{XC} \cdot \frac{CY'}{Y'A} \cdot \frac{AZ}{ZB} = -1 = \frac{BX}{XC} \cdot \frac{CY}{YA} \cdot \frac{AZ}{ZB}.$$

It follows that

$$\frac{CY'}{Y'A} = \frac{CY}{YA}.$$

The points Y' and Y divide the segment CA in the same ratio. These must be the same point, and X, Y, Z are collinear.

Exercise

1. M is a point on the median AD of $\triangle ABC$ such that $AM : MD = p : q$. The line CM intersects the side AB at N . Find the ratio $AN : NB$.
3
2. The incircle of $\triangle ABC$ touches the sides BC, CA, AB at D, E, F respectively. Suppose $AB \neq AC$. The line joining E and F meets BC at P . Show that P and D divide BC harmonically.

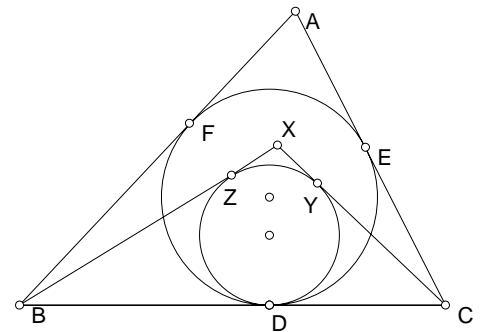
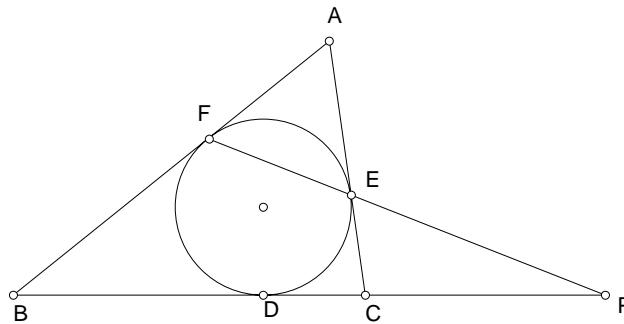

³Answer: $AN : NB = p : 2q$.

3. The incircle of $\triangle ABC$ touches the sides BC, CA, AB at D, E, F respectively. X is a point inside $\triangle ABC$ such that the incircle of $\triangle XBC$ touches BC at D also, and touches CX and XB at Y and Z respectively. Show that E, F, Z, Y are concyclic.⁴

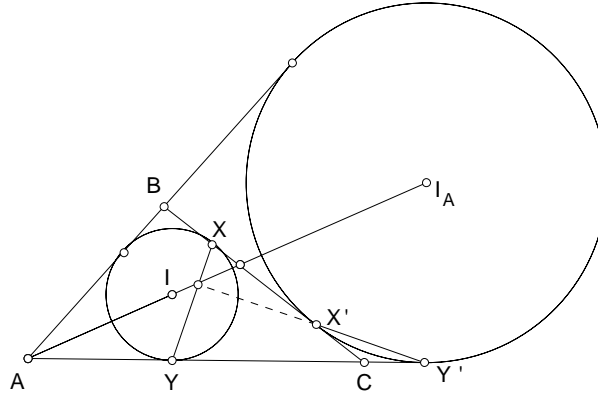

4. Given a triangle ABC , let the incircle and the ex-circle on BC touch the side BC at X and X' respectively, and the line AC at Y and Y' respectively. Then the lines XY and $X'Y'$ intersect on the bisector of angle A , at the projection of B on this bisector.

7.4 The Ceva Theorem

Let X, Y, Z be points on the lines BC, CA, AB respectively. The lines AX, BY, CZ are concurrent if and only if

$$\frac{BX}{XC} \cdot \frac{CY}{YA} \cdot \frac{AZ}{ZB} = +1.$$

Proof. (\implies) Suppose the lines AX, BY, CZ intersect at a point P . Consider the line BPY cutting the sides of $\triangle CAX$. By Menelaus' theorem,

$$\frac{CY}{YA} \cdot \frac{AP}{PX} \cdot \frac{XB}{BC} = -1, \quad \text{or} \quad \frac{CY}{YA} \cdot \frac{PA}{XP} \cdot \frac{BX}{BC} = +1.$$

⁴IMO 1996.

Also, consider the line CPZ cutting the sides of $\triangle ABX$. By Menelaus' theorem again,

$$\frac{AZ}{ZB} \cdot \frac{BC}{CX} \cdot \frac{XP}{PA} = -1, \quad \text{or} \quad \frac{AZ}{ZB} \cdot \frac{BC}{XC} \cdot \frac{XP}{PA} = +1.$$

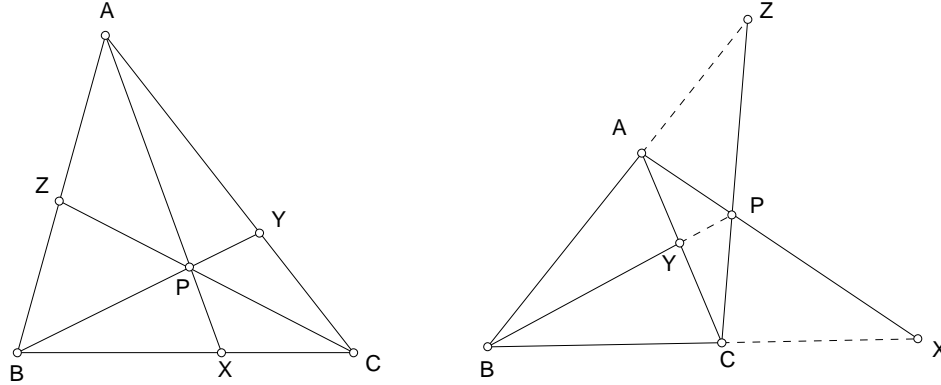

Multiplying the two equations together, we have

$$\frac{CY}{YA} \cdot \frac{AZ}{ZB} \cdot \frac{BX}{XC} = +1.$$

(\Leftarrow) Exercise.

7.5 Examples

7.5.1 The centroid

If D, E, F are the midpoints of the sides BC, CA, AB of $\triangle ABC$, then clearly

$$\frac{AF}{FB} \cdot \frac{BD}{DC} \cdot \frac{CE}{EA} = 1.$$

The medians AD, BE, CF are therefore concurrent (at the centroid G of the triangle).

Consider the line BGE intersecting the sides of $\triangle ADC$. By the Menelaus theorem,

$$-1 = \frac{AG}{GD} \cdot \frac{DB}{BC} \cdot \frac{CE}{EA} = \frac{AG}{GD} \cdot \frac{-1}{2} \cdot \frac{1}{1}.$$

It follows that $AG : GD = 2 : 1$. The centroid of a triangle divides each median in the ratio $2 : 1$.

7.5.2 The incenter

Let X, Y, Z be points on BC, CA, AB such that

$$\begin{aligned} AX & \text{ bisects } \angle BAC \\ BY & \text{ bisects } \angle CBA, \\ CZ & \text{ bisects } \angle ACB \end{aligned}$$

then

$$\frac{AZ}{ZB} = \frac{b}{a}, \quad \frac{BX}{XC} = \frac{c}{b}, \quad \frac{CY}{YA} = \frac{a}{c}.$$

It follows that

$$\frac{AZ}{ZB} \cdot \frac{BX}{XC} \cdot \frac{CY}{YA} = \frac{b}{a} \cdot \frac{c}{b} \cdot \frac{a}{c} = +1,$$

and AX, BY, CZ are concurrent, at the incenter I of the triangle.

Exercise

- Use the Ceva theorem to justify the existence of the excenters of a triangle.
- Let AX, BY, CZ be cevians of $\triangle ABC$ intersecting at a point P .
 - Show that if AX bisects angle A and $BX \cdot CY = XC \cdot BZ$, then $\triangle ABC$ is isosceles.
 - Show if AX, BY, CZ are bisectors and $BP \cdot ZP = BZ \cdot AP$, then $\triangle ABC$ is a right triangle.
- Suppose three cevians, each through a vertex of a triangle, trisect each other. Show that these are the medians of the triangle.
- ABC is a right triangle. Show that the lines AP, BQ , and CR are concurrent.

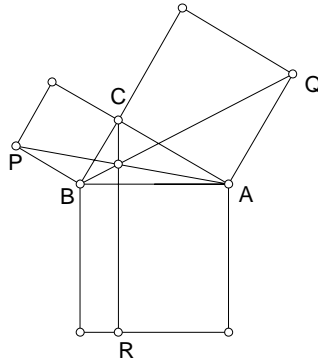

5. ⁵ If three equal cevians divide the sides of a triangle in the same ratio and the same sense, the triangle must be equilateral.
6. Suppose the bisector of angle A , the median on the side b , and the altitude on the side c are concurrent. Show that ⁶

$$\cos \alpha = \frac{c}{b+c}.$$

7. Given triangle ABC , construct points A', B', C' such that ABC' , BCA' and CAB' are isosceles triangles satisfying

$$\angle BCA' = \angle CBA' = \alpha, \quad \angle CAB' = \angle ACB' = \beta, \quad \angle ABC' = \angle BAC' = \gamma.$$
 Show that $AA', BB',$ and CC' are concurrent. ⁷

7.6 Trigonometric version of the Ceva Theorem

7.6.1

Let X be a point on the side BC of triangle ABC such that the directed angles $\angle BAX = \alpha_1$ and $\angle XAC = \alpha_2$. Then

$$\frac{BX}{XC} = \frac{c}{b} \cdot \frac{\sin \alpha_1}{\sin \alpha_2}.$$

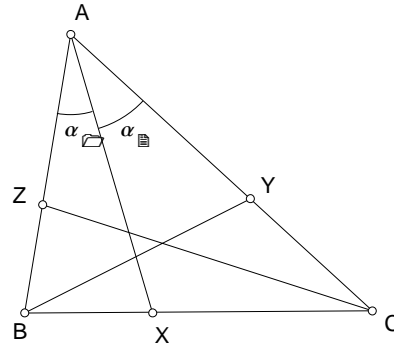
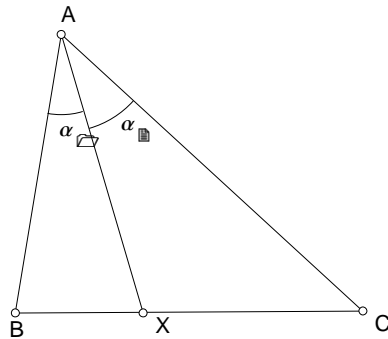

Proof. By the sine formula,

$$\frac{BX}{XC} = \frac{BX/AX}{XC/AX} = \frac{\sin \alpha_1 / \sin \beta}{\sin \alpha_2 / \sin \gamma} = \frac{\sin \gamma}{\sin \beta} \cdot \frac{\sin \alpha_1}{\sin \alpha_2} = \frac{c}{b} \cdot \frac{\sin \alpha_1}{\sin \alpha_2}.$$

⁵Klamkin

⁶AMME 263; CMJ 455.

⁷ $A'B'C'$ is the tangential triangle of ABC .

7.6.2

Let X, Y, Z be points on the lines BC, CA, AB respectively. The lines AX, BY, CZ are concurrent if and only if

$$\frac{\sin \alpha_1}{\sin \alpha_2} \cdot \frac{\sin \beta_1}{\sin \beta_2} \cdot \frac{\sin \gamma_1}{\sin \gamma_2} = +1.$$

Proof. Analogous to

$$\frac{BX}{XC} = \frac{c}{b} \cdot \frac{\sin \alpha_1}{\sin \alpha_2}$$

are

$$\frac{CY}{YA} = \frac{a}{c} \cdot \frac{\sin \beta_1}{\sin \beta_2}, \quad \frac{AZ}{ZB} = \frac{b}{a} \cdot \frac{\sin \gamma_1}{\sin \gamma_2}.$$

Multiplying the three equations together,

$$\frac{AZ}{ZB} \cdot \frac{BX}{XC} \cdot \frac{CY}{YA} = \frac{\sin \alpha_1}{\sin \alpha_2} \cdot \frac{\sin \beta_1}{\sin \beta_2} \cdot \frac{\sin \gamma_1}{\sin \gamma_2}.$$

Exercise

1. Show that the three altitudes of a triangle are concurrent (at the orthocenter H of the triangle).
2. Let A', B', C' be points outside $\triangle ABC$ such that $A'BC, B'CA$ and $C'AB$ are similar isosceles triangles. Show that AA', BB', CC' are concurrent.⁸

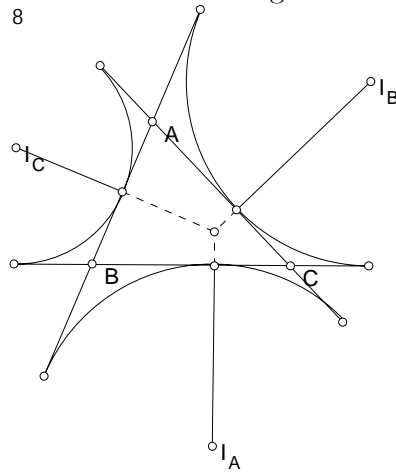

⁸Solution. Let X be the intersection of AA' and BC . Then $\frac{BX}{XC} = \frac{\sin(\beta+\omega)}{\sin(\gamma+\omega)} \cdot \frac{\sin \gamma}{\sin \beta}$.

3. Show that the perpendiculars from I_A to BC , from I_B to CA , and from I_C to AB are concurrent.⁹

7.7 Mixtilinear incircles

Suppose the mixtilinear incircles in angles A, B, C of triangle ABC touch the circumcircle respectively at the points A', B', C' . The segments $AA', BB',$ and CC' are concurrent.

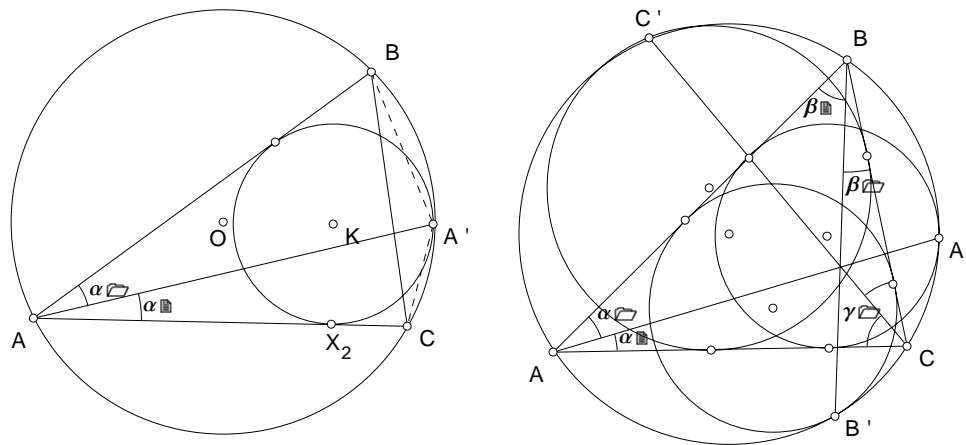

Proof. We examine how the mixtilinear incircle divides the minor arc BC of the circumcircle. Let A' be the point of contact. Denote $\alpha_1 := \angle A'AB$ and $\alpha_2 := \angle A'AC$. Note that the circumcenter O , and the points K, A' are collinear. In triangle KOC , we have

$$OK = R - \rho_1, \quad OC = R, \quad \angle KOC = 2\alpha_2,$$

where R is the circumradius of triangle ABC . Note that $CX_2 = \frac{b(s-c)}{s}$, and $KC^2 = \rho_1^2 + CX_2^2$. Applying the cosine formula to triangle KOC , we have

$$2R(R - \rho_1) \cos 2\alpha_2 = (R - \rho_1)^2 + R^2 - \rho_1^2 - \left(\frac{b(s-c)}{s}\right)^2.$$

Since $\cos 2\alpha_2 = 1 - 2 \sin^2 \alpha_2$, we obtain, after rearrangement of the terms,

$$\sin \alpha_2 = \frac{b(s-c)}{s} \cdot \frac{1}{\sqrt{2R(R - \rho_1)}}.$$

⁹Consider these as cevians of triangle $I_A I_B I_C$.

Similarly, we obtain

$$\sin \alpha_1 = \frac{c(s-b)}{s} \cdot \frac{1}{\sqrt{2R(R-\rho)}}.$$

It follows that

$$\frac{\sin \alpha_1}{\sin \alpha_2} = \frac{c(s-b)}{b(s-c)}.$$

If we denote by B' and C' the points of contact of the circumcircle with the mixtilinear incircles in angles B and C respectively, each of these divides the respective minor arcs into the ratios

$$\frac{\sin \beta_1}{\sin \beta_2} = \frac{a(s-c)}{c(s-a)}, \quad \frac{\sin \gamma_1}{\sin \gamma_2} = \frac{b(s-a)}{a(s-b)}.$$

From these,

$$\frac{\sin \alpha_1}{\sin \alpha_2} \cdot \frac{\sin \beta_1}{\sin \beta_2} \cdot \frac{\sin \gamma_1}{\sin \gamma_2} = \frac{a(s-c)}{c(s-a)} \cdot \frac{b(s-a)}{a(s-b)} \cdot \frac{c(s-b)}{b(s-c)} = +1.$$

By the Ceva theorem, the segments AA' , BB' and CC' are concurrent.

Exercise

1. The mixtilinear incircle in angle A of triangle ABC touches its circumcircle at A' . Show that AA' is a common tangent of the mixtilinear incircles of angle A in triangle $AA'B$ and of angle A in triangle $AA'C$.

10

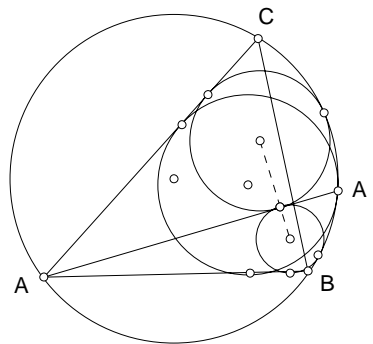

¹⁰Problem proposal to Crux Mathematicorum.

7.8 Duality

Given a triangle ABC , let

$$\begin{array}{lll} X, & X' & BC \\ Y, & Y' & \text{be harmonic conjugates with respect to the side } CA. \\ Z, & Z' & AB \end{array}$$

The points X', Y', Z' are collinear if and only if the cevians AX, BY, CZ are concurrent.

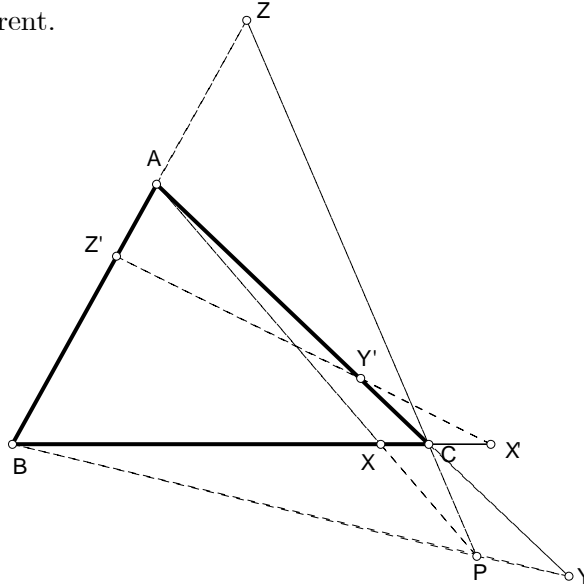

Proof. By assumption,

$$\frac{BX'}{X'C} = -\frac{BX}{XC}, \quad \frac{CY'}{Y'A} = -\frac{CY}{YA}, \quad \frac{AZ'}{Z'B} = -\frac{AZ}{ZB}.$$

It follows that

$$\frac{BX'}{X'C} \cdot \frac{CY'}{Y'A} \cdot \frac{AZ'}{Z'B} = -1 \quad \text{if and only if} \quad \frac{BX}{XC} \cdot \frac{CY}{YA} \cdot \frac{AZ}{ZB} = +1.$$

The result now follows from the Menelaus and Ceva theorems.

7.8.1 Ruler construction of harmonic conjugate

Given two points A and B , the harmonic conjugate of a point P can be constructed as follows. Choose a point C outside the line AB . Draw the

lines CA , CB , and CP . Through P draw a line intersecting CA at Y and CB at X . Let Z be the intersection of the lines AX and BY . Finally, let Q be the intersection of CZ with AB . Q is the harmonic conjugate of P with respect to A and B .

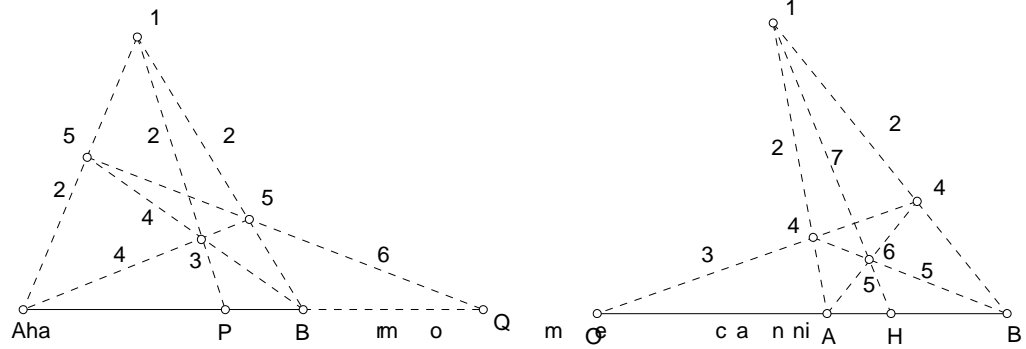

theorem to the triangle XAB and transversal $B'C'P$, we have

$$\frac{XAB}{XCA} = \frac{A'B'R}{C'A'Q}$$

$$\frac{XA'}{A'A} \cdot \frac{AR}{RB} \cdot \frac{BB'}{B'X} = -1, \quad \frac{XB'}{B'B} \cdot \frac{BP}{PC} \cdot \frac{CC'}{C'X} = -1, \quad \frac{XC'}{C'C} \cdot \frac{CQ}{QA} \cdot \frac{AA'}{A'X} = -1.$$

Multiplying these three equation together, we obtain

$$\frac{AR}{RB} \cdot \frac{BP}{PC} \cdot \frac{CQ}{QA} = -1.$$

By Menelaus' theorem again, the points P, Q, R are concurrent.

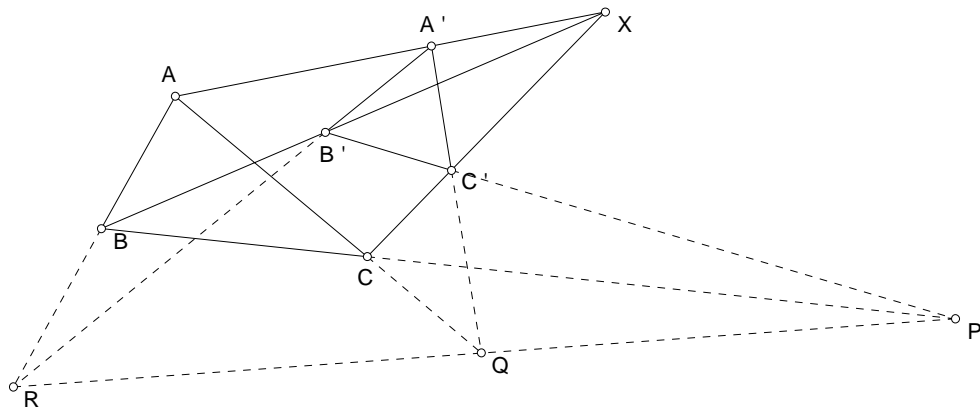

7.9.2

Two triangles satisfying the conditions of the preceding theorem are said to be perspective. X is the center of perspective, and the line PQR the axis of perspective.

7.9.3

Given two triangles ABC and $A'B'C'$, if the lines AA', BB', CC' are parallel, then the intersections of the pairs of lines $\frac{AB}{A'B'}, \frac{BC}{B'C'}, \frac{CA}{C'A'}$ are collinear.

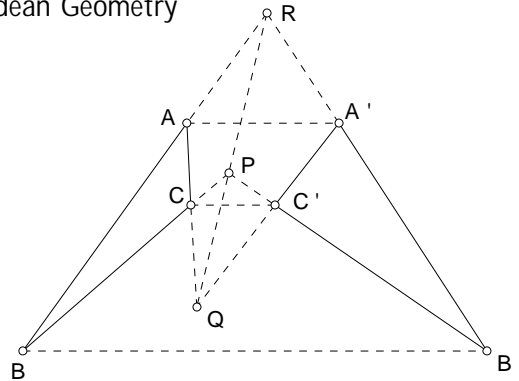

Proof.

$$\frac{BP}{PC} \cdot \frac{CQ}{QA} \cdot \frac{AR}{RB} = \left(-\frac{BB'}{CC'}\right) \left(-\frac{CC'}{AA'}\right) \left(-\frac{AA'}{BB'}\right) = -1.$$

7.9.4

If the corresponding sides of two triangles are pairwise parallel, then the lines joining the corresponding vertices are concurrent.

Proof. Let X be the intersection of BB' and CC' . Then

$$\frac{CX}{XC'} = \frac{BC}{B'C'} = \frac{CA}{C'A'}.$$

The intersection of AA' and CC' therefore coincides with X .

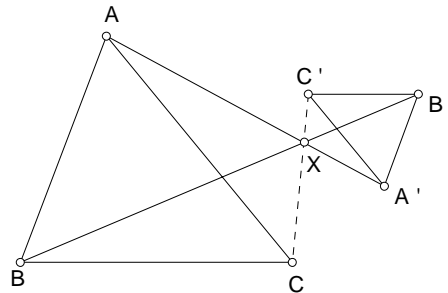

7.9.5

Two triangles whose sides are parallel in pairs are said to be homothetic. The intersection of the lines joining the corresponding vertices is the homothetic center. Distances of corresponding points to the homothetic center are in the same ratio as the lengths of corresponding sides of the triangles.

Chapter 8

Homogeneous coordinates

8.1 Coordinates of points on a line

8.1.1

Let B and C be two distinct points. Each point X on the line BC is uniquely determined by the ratio $BX : XC$. If $BX : XC = \lambda' : \lambda$, then we say that X has homogeneous coordinates $\lambda : \lambda'$ with respect to the segment BC . Note that $\lambda + \lambda' \neq 0$ unless X is the point at infinity on the line BC . In this case, we shall normalize the homogeneous coordinates to obtain the barycentric coordinate of $X : \frac{\lambda}{\lambda + \lambda'}B + \frac{\lambda'}{\lambda + \lambda'}C$.

Exercise

1. Given two distinct points B, C , and real numbers y, z , satisfying $y + z = 1$, $yB + zC$ is the point on the line BC such that $BX : XC = z : y$.
2. If $\lambda \neq \frac{1}{2}$, the harmonic conjugate of the point $P = (1 - \lambda)A + \lambda B$ is the point

$$P' = \frac{1 - \lambda}{1 - 2\lambda}A - \frac{\lambda}{1 - 2\lambda}B.$$

8.2 Coordinates with respect to a triangle

Given a triangle ABC (with positive orientation), every point P on the plane has barycentric coordinates of the form $P : xA + yB + zC$, $x + y + z = 1$.

This means that the areas of the oriented triangles PBC , PCA and PAB are respectively

$$\triangle PBC = x\Delta, \quad \triangle PCA = y\Delta, \quad \text{and} \quad \triangle PAB = z\Delta.$$

We shall often identify a point with its barycentric coordinates, and write $P = xA + yB + zC$. In this case, we also say that P has homogeneous coordinates $x : y : z$ with respect to triangle ABC .

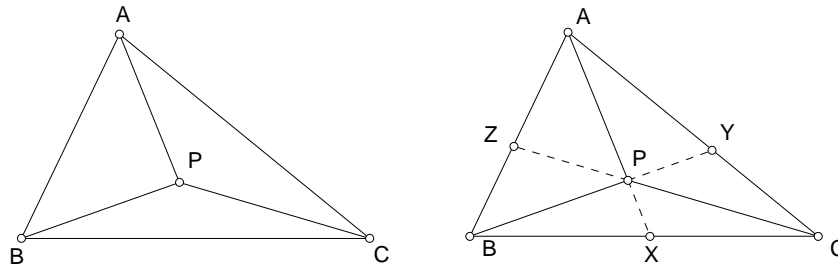

Exercises

If P has homogeneous coordinates of the form $0 : y : z$, then P lies on the line BC .

8.2.1

Let X be the intersection of the lines AP and BC . Show that X has homogeneous coordinates $0 : y : z$, and hence barycentric coordinates

$$X = \frac{y}{y+z}B + \frac{z}{y+z}C.$$

This is the point at infinity if and only if $y+z=0$. Likewise, if Y and Z are respectively the intersections of BP with CA , and of CP with AB , then

$$Y = \frac{x}{z+x}A + \frac{z}{z+x}C, \quad Z = \frac{x}{x+y}A + \frac{y}{x+y}B.$$

8.2.2 Ceva Theorem

If X , Y , and Z are points on the lines BC , CA , and AB respectively such that

$$\begin{aligned} BX : XC &= \mu : \nu, \\ AY : YC &= \lambda : \nu, \\ AZ : ZB &= \lambda : \mu, \end{aligned}$$

and if $\frac{1}{\lambda} + \frac{1}{\mu} + \frac{1}{\nu} \neq 0$, then the lines AX , BY , CZ intersect at the point P with homogeneous coordinates

$$\frac{1}{\lambda} : \frac{1}{\mu} : \frac{1}{\nu} = \mu\nu : \lambda\nu : \lambda\mu$$

with respect to the triangle ABC . In barycentric coordinates,

$$P = \frac{1}{\mu\nu + \lambda\nu + \lambda\mu}(\mu\nu \cdot A + \lambda\nu \cdot B + \lambda\mu \cdot C).$$

8.2.3 Examples

Centroid

The midpoints D , E , F of the sides of triangle ABC divide the sides in the ratios

$$\begin{array}{rcl} BD & : & DC = 1 : 1, \\ AE & : & EC = 1 : 1, \\ AF & : & FB = 1 : 1. \end{array}$$

The medians intersect at the centroid G , which has homogeneous coordinates $1 : 1 : 1$, or

$$G = \frac{1}{3}(A + B + C).$$

Incenter

The (internal) bisectors of the sides of triangle ABC intersect the sides at X , Y , Z respectively with

$$\begin{array}{rcl} BX & : & XC = c : b = ac : ab, \\ AY & : & YC = c : a = bc : ab, \\ AZ & : & ZB = b : a = bc : ac. \end{array}$$

These bisectors intersect at the incenter I with homogeneous coordinates

$$\frac{1}{bc} : \frac{1}{ca} : \frac{1}{ab} = a : b : c.$$

8.2.4 Menelaus Theorem

If X , Y , and Z are points on the lines BC , CA , and AB respectively such that

$$\begin{array}{rcl} BX : XC & = & \mu : -\nu, \\ AY : YC & = & -\lambda : \nu, \\ AZ : ZB & = & \lambda : -\mu, \end{array}$$

then the points X , Y , Z are collinear.

8.2.5 Example

Consider the tangent at A to the circumcircle of triangle ABC . Suppose $AB \neq AC$. This intersects the line BC at a point X . To determine the coordinates of X with respect to BC , note that $BX \cdot CX = AX^2$. From this,

$$\frac{BX}{CX} = \frac{BX \cdot CX}{CX^2} = \frac{AX^2}{CX^2} = \left(\frac{AX}{CX}\right)^2 = \left(\frac{AB}{CA}\right)^2 = \frac{c^2}{b^2},$$

where we have made use of the similarity of the triangles ABX and CAX . Therefore,

$$BX : XC = c^2 : -b^2.$$

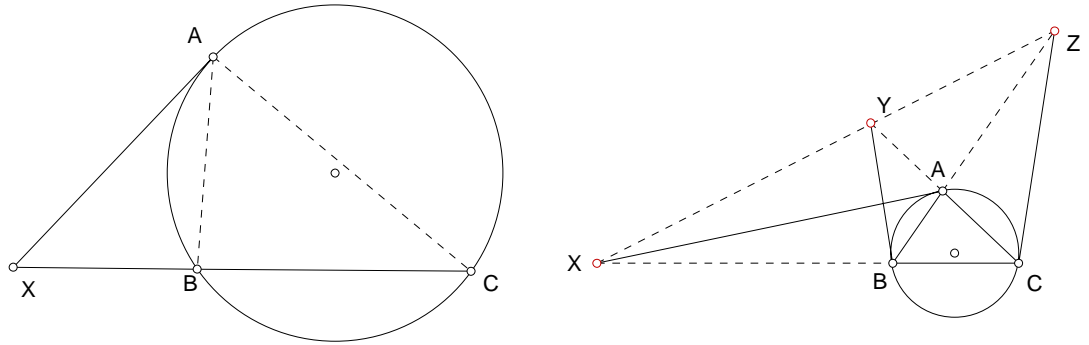

Similarly, if the tangents at B and C intersect respectively the lines CA and AB at Y and Z , we have

$$\begin{array}{rcl} BX : XC & = & c^2 : -b^2 = \frac{1}{b^2} : -\frac{1}{c^2}, \\ AY : YC & = & -c^2 : a^2 = -\frac{1}{a^2} : \frac{1}{c^2}, \\ AZ : ZB & = & b^2 : -a^2 = \frac{1}{a^2} : -\frac{1}{b^2}. \end{array}$$

From this, it follows that the points X , Y , Z are collinear.

8.3 The centers of similitude of two circles

8.3.1 External center of similitude

Consider two circles, centers A , B , and radii r_1 and r_2 respectively.

Suppose $r_1 \neq r_2$. Let AP and BQ be (directly) parallel radii of the circles. The line PQ always passes a fixed point K on the line AB . This is the **external center of similitude** of the two circles, and divides the segment AB externally in the ratio of the radii:

$$AK : KB = r_1 : -r_2.$$

The point K has homogeneous coordinates $r_2 : -r_1$ with respect to the segment AB ,

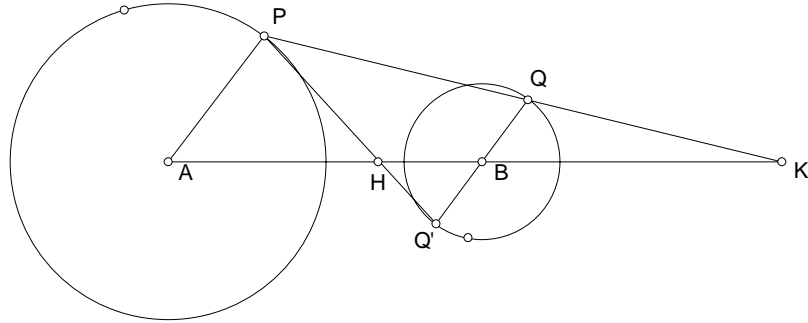

8.3.2 Internal center of similitude

If AP and BQ' are oppositely parallel radii of the circles, then the line PQ' always passes a fixed point H on the line AB . This is the **internal center of similitude** of the two circles, and divides the segment AB internally in the ratio of the radii:

$$AH : HB = r_1 : r_2.$$

The point H has homogeneous coordinates $r_2 : r_1$ with respect to the segment AB .

Note that H and K divide the segment AB harmonically.

Example

Consider three circles $O_i(r_i)$, $i = 1, 2, 3$, whose centers are not collinear and whose radii are all distinct. Denote by C_k , $k = 1, 2, 3$, the internal center of similitude of the circles (O_i) and (O_j) , $i, j \neq k$. Since

$$\begin{aligned} O_2C_1 : C_1O_3 &= r_2 : r_3, \\ O_1C_2 : C_2O_3 &= r_1 : r_3, \\ O_1C_3 : C_3O_2 &= r_1 : r_2, \end{aligned}$$

the lines O_1A_1 , O_2A_2 , O_3A_3 are concurrent, their intersection being the point

$$\frac{1}{r_1} : \frac{1}{r_2} : \frac{1}{r_3}$$

with respect to the triangle $O_1O_2O_3$.

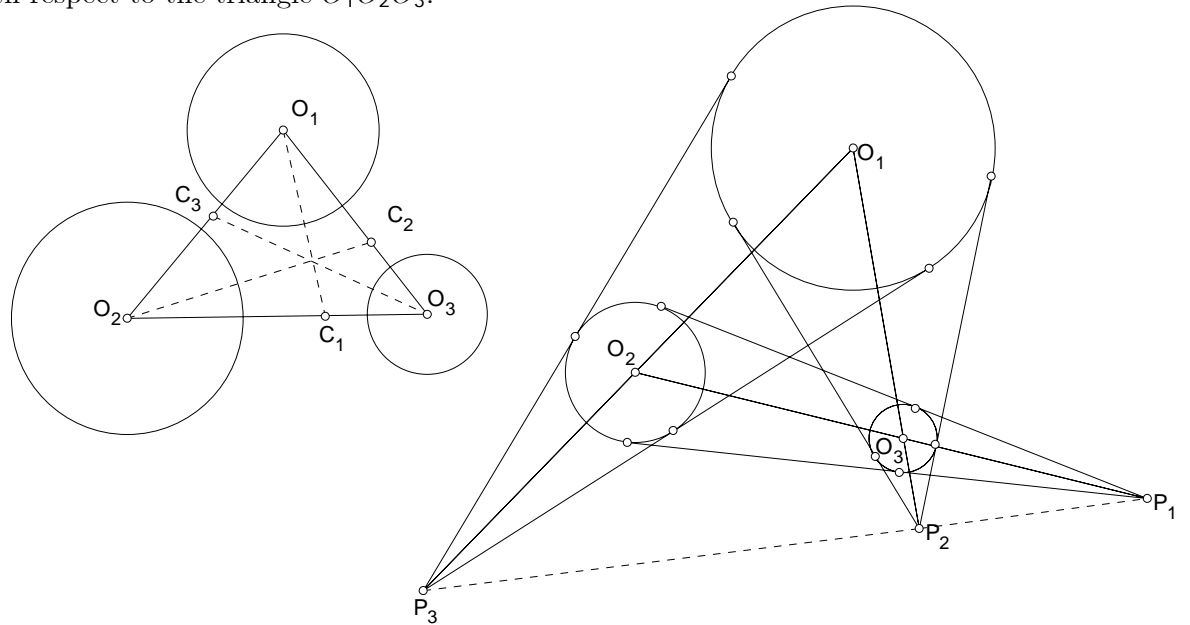

Exercise

- Let P_1 be the internal center of similitude of the circles $(O_2), (O_3)$.
 Let P_2 be the external center of similitude of the circles $(O_3), (O_1)$.
 Let P_3 be the external center of similitude of the circles $(O_1), (O_2)$.
 Find the homogeneous coordinates of the points P_1, P_2, P_3 with respect to the triangle $O_1O_2O_3$, and show that they are collinear.

2. Given triangle ABC , the perpendiculars from the excenters I_C to I_B
 I_A
 AB I_C AC A'
 BC and I_A to CA intersect at B' . Show that the lines AA' , BB' ,
 CA I_B AB C'
 and CC' are concurrent. ¹

8.4

Consider a circle with center K , radius ρ , tangent to the sides AB and AC , and the circumcircle of triangle ABC . Let $\epsilon = 1$ or -1 according as the tangency with the circumcircle is external or internal. Since $AK : AI = \rho : r$, $AK : KI = \rho : -(\rho - r)$,

$$K = \frac{1}{r}[\rho I - (\rho - r)A].$$

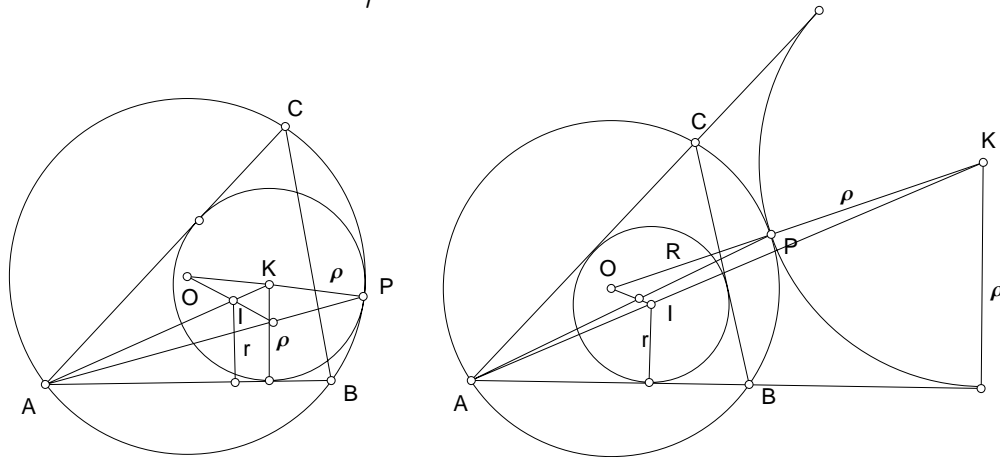

Also, let P be the point of contact with the circumcircle. Since $OP : KP = R : \epsilon\rho$, we have $OP : PK = R : -\epsilon\rho$, and

$$P = \frac{1}{R + \epsilon\rho}(R \cdot K - \epsilon\rho \cdot O) = \frac{-\epsilon\rho}{R - \epsilon\rho} \cdot O + \frac{R}{R - \epsilon\rho} \cdot K.$$

Now, every point on the line AP is of the form

$$\lambda P + (1 - \lambda)A = \frac{\lambda\rho}{r(R - \epsilon\rho)}(-\epsilon r \cdot O + R \cdot I) + f(\lambda)A,$$

¹CMJ408.894.408.S905.

for some real number λ . Assuming A not on the line OI , it is clear that AP intersects OI at a point with homogeneous $-\epsilon r : R$ with respect to the segment OI . In other words,

$$OX : XI = R : -\epsilon r.$$

This is the ^{external}/_{internal} center of similitude of the circumcircle (O) and the incircle (I) according as $\epsilon = \frac{-1}{1}$, i.e., the circle (K) touching the circumcircle of ABC ^{internally}/_{externally}.

In barycentric coordinates, this is the point

$$X = \frac{1}{R - \epsilon r}(-\epsilon r \cdot O + R \cdot I).$$

This applies to the mixtilinear incircles (excircles) at the other two vertices too.

8.4.1 Theorem

Let ABC be a given triangle. The three segments joining the each vertex of the triangle to the point of contact of the corresponding mixtilinear ^{incircles}/_{excircles} are concurrent at ^{external}/_{internal} center of similitude of the circumcircle and the incircle.

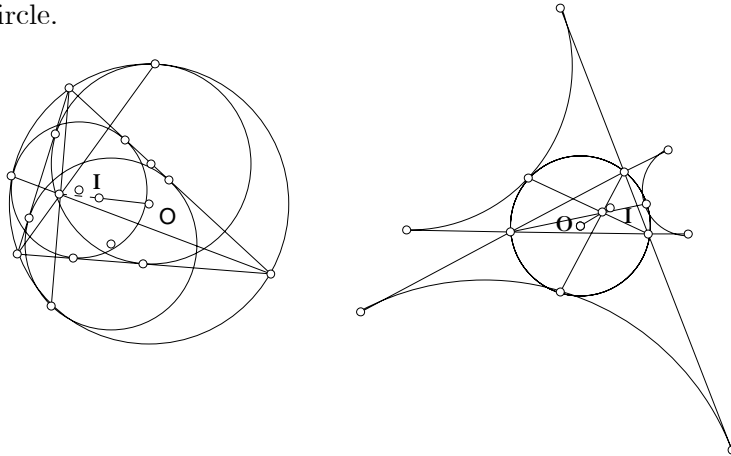

8.5 Isotomic conjugates

Let X be a point on the line BC . The unique point X' on the line satisfying $BX = -CX'$ is called the isotomic conjugate of X with respect to the segment BC . Note that

$$\frac{BX'}{X'C} = \left(\frac{BX}{XC}\right)^{-1}.$$

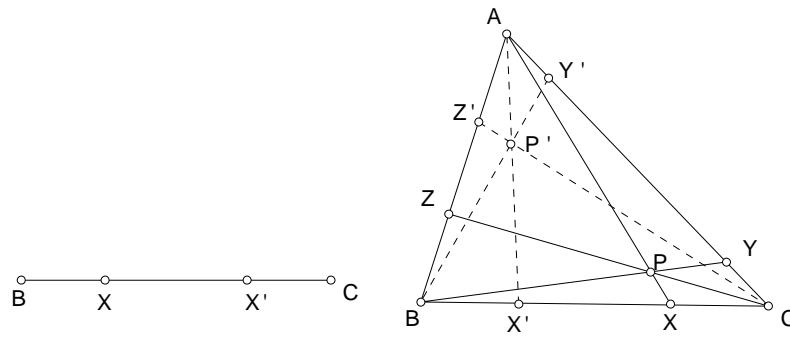

8.5.1

Let P be a point with homogeneous coordinates $x : y : z$ with respect to a triangle ABC . Denote by X, Y, Z the intersections of the lines AP, BP, CP with the sides BC, CA, AB . Clearly,

$$BX : XC = z : y, \quad CY : YA = x : z, \quad AZ : ZB = y : x.$$

If X', Y' , and Z' are the isotomic conjugates of X, Y , and Z on the respective sides, then

$$\begin{aligned} BX' : X'C &= y : z, \\ AY' : Y'C &= x : z, \\ AZ' : Z'B &= x : y. \end{aligned}$$

It follows that AX', BY' , and CZ' are concurrent. The intersection P' is called the isotomic conjugate of P (with respect to the triangle ABC). It has homogeneous coordinates

$$\frac{1}{x} : \frac{1}{y} : \frac{1}{z}.$$

Exercise

1. If $X = yB + zC$, then the isotomic conjugate is $X' = zB + yC$.
2. X', Y', Z' are collinear if and only if X, Y, Z are collinear.

8.5.2 Gergonne and Nagel points

Suppose the incircle $I(r)$ of triangle ABC touches the sides $BC, CA,$ and AB at the points $X, Y,$ and Z respectively.

$$\begin{array}{rcl} BX & : & XC = s - b & : & s - c, \\ AY & : & YC = s - a & : & s - c, \\ AZ & : & ZB = s - a & : & s - b. \end{array}$$

This means the cevians AX, BY, CZ are concurrent. The intersection is called the Gergonne point of the triangle, sometimes also known as the Gergonne point.

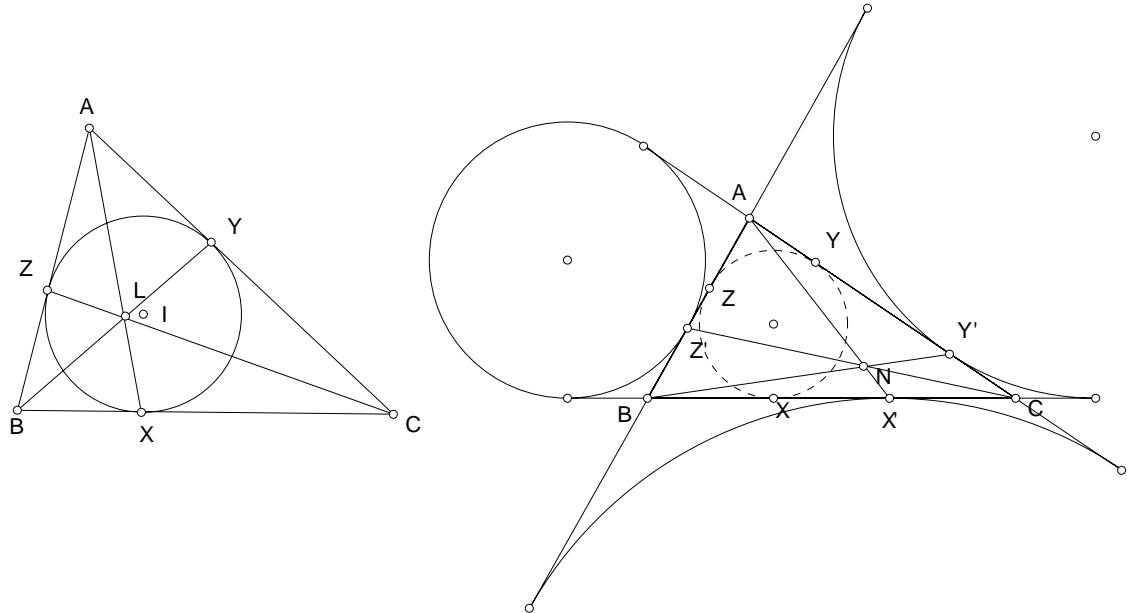

Let X', Y', Z' be the isotomic conjugates of X, Y, Z on the respective sides. The point X' is indeed the point of contact of the excircle $I_A(r_1)$ with the side BC ; similarly for Y' and Z' . The cevians AX', BY', CZ' are

YIU: Euclidean Geometry

concurrent. The intersection of the three lines is the isotomic conjugate of the point.

Exercise

1. Which point is the isotomic conjugate of the centroid of a triangle? ²
2. Suppose the excircle of a triangle is tangent to the side BC at N and the line AN is extended to meet the circumcircle at X' . Show that $AN : NX' = a : b$.
3. Suppose the incircle of a triangle is tangent to the sides BC, CA, AB at D, E, F respectively. Let AD, BE, CF be extended to meet the circumcircle at Y, Z respectively. Let Y', Z' be the points on the circumcircle symmetrically opposite to Y, Z respectively. Show that AY', BZ', CX' are concurrent. ⁴

8.6 Isogonal conjugate

8.6.1

Given a triangle, two cevians from a vertex to the opposite side are symmetric with respect to the angle bisector of that vertex.

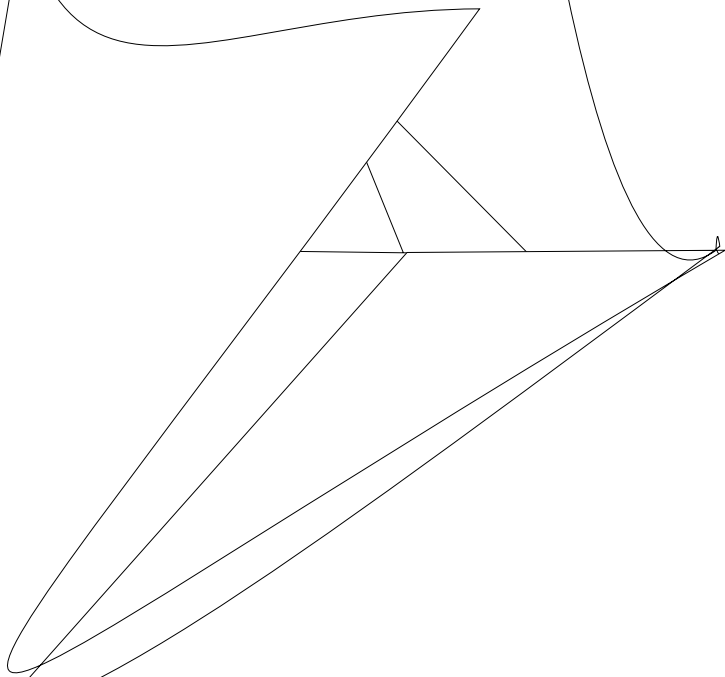

Exercise

1. Show that

$$\frac{BX^*}{X^*C} = \frac{c^2}{b^2} \cdot \frac{XC}{BX}.$$

2. Given a triangle ABC , let D and E be points on BC such that $\angle BAD = \angle CAE$. Suppose the incircles of the triangles ABD and ACE touch the side BC at M and N respectively. Show that

$$\frac{1}{BM} + \frac{1}{MD} = \frac{1}{CN} + \frac{1}{NE}.$$

8.6.2

Given a point P , let l_a, l_b, l_c be the respective cevians through P the vertices A, B, C of $\triangle ABC$. Denote by l_a^*, l_b^*, l_c^* their isogonal cevians. Using the trigonometric version of the Ceva theorem, it is easy to see that the cevians l_a^*, l_b^*, l_c^* are concurrent if and only if l_a, l_b, l_c are concurrent. Their intersection P^* is called the **isogonal conjugate** of P with respect to $\triangle ABC$.

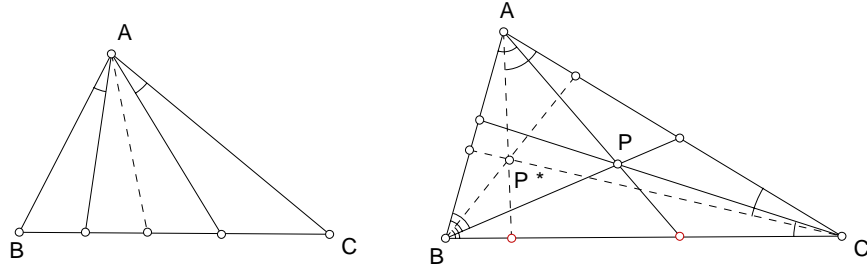

8.6.3

Suppose P has homogeneous coordinates $x : y : z$ with respect to triangle ABC . If the cevian AP and its isogonal cevian respectively meet the side BC at X and X^* , then since

CA at Y and Y^* , then since
 AB at Z and Z^*

$$BX : XC = z : y, \quad AY : YC = z : x, \quad AZ : ZB = y : x,$$

we have

$$\begin{array}{l} BX^* : X^*C = c^2y : b^2z = \frac{y}{b^2} : \frac{z}{c^2}, \\ AY^* : Y^*C = c^2x : a^2z = \frac{x}{a^2} : \frac{z}{c^2}, \\ AZ^* : Z^*B = b^2x : a^2y = \frac{x}{a^2} : \frac{y}{b^2}. \end{array}$$

From this it follows that the isogonal conjugate P^* has homogeneous coordinates

$$\frac{a^2}{x} : \frac{b^2}{y} : \frac{c^2}{z}.$$

8.6.4 Circumcenter and orthocenter as isogonal conjugates

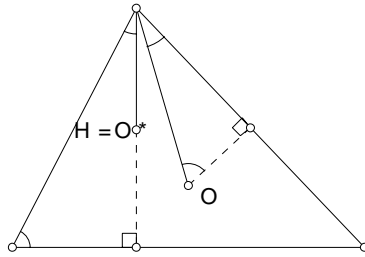

The homogeneous coordinates of the circumcenter are

$$a \cos \alpha : b \cos \beta : c \cos \gamma = a^2(b^2 + c^2 - a^2) : b^2(c^2 + a^2 - b^2) : c^2(a^2 + b^2 - c^2).$$

Exercise

1. Show that a triangle is isosceles if its circumcenter, orthocenter, and an excenter are collinear.⁵

8.6.5 The symmedian point

The symmedian point K is the isogonal conjugate of the centroid G . It has homogeneous coordinates,

$$K = a^2 : b^2 : c^2.$$

⁵Solution (Leon Bankoff) This is clear when $\alpha = 90^\circ$. If $\alpha \neq 90^\circ$, the lines AO and AH are isogonal with respect to the bisector Al_A , if O, H, l_A are collinear, then $\angle OAl_A = \angle HAl_A = 0$ or 180° , and the altitude AH falls along the line Al_A . Hence, the triangle is isosceles.

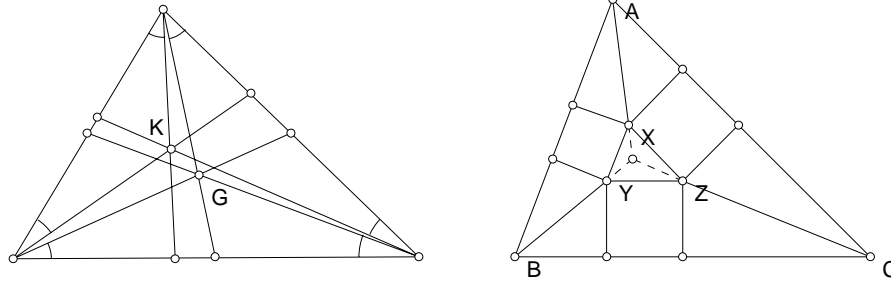

Exercise

1. Show that the lines joining each vertex to a common corner of the squares meet at the symmedian point of triangle ABC .

8.6.6 The symmedians

If D^* is the point on the side BC of triangle ABC such that AD^* is the isogonal cevian of the median AD , AD^* is called the **symmedian** on the side BC . The length of the symmedian is given by

$$t_a = \frac{2bc}{b^2 + c^2} \cdot m_a = \frac{bc\sqrt{2(b^2 + c^2) - a^2}}{b^2 + c^2}.$$

Exercise

1. $t_a = t_b$ if and only if $a = b$.
2. If an altitude of a triangle is also a symmedian, then either it is isosceles or it contains a right angle. ⁶

8.6.7 The exsymmedian points

Given a triangle ABC , complete it to a parallelogram $BACA'$. Consider the isogonal cevian BP of the side BA' . Since each of the pairs BP, BA' , and BA, BC is symmetric with respect to the bisector of angle B , $\angle PBA = \angle A'BC = \angle BCA$. It follows that BP is tangent to the circle ABC at B . Similarly, the isogonal cevian of CA' is the tangent at C to the circumcircle of triangle ABC . The intersection of these two tangents at B and C to the circumcircle is therefore the isogonal conjugate of A' with respect to

⁶Cruze 960.

the triangle. This is the exsymmedian point K_A of the triangle. Since A' has homogeneous coordinates $-1 : 1 : 1$ with respect to triangle ABC , the exsymmedian point K_A has homogeneous coordinates $-a^2 : b^2 : c^2$. The other two exsymmedian points K_B and K_C are similarly defined. These exsymmedian points are the vertices of the tangential triangle bounded by the tangents to the circumcircle at the vertices.

$$\begin{aligned} K_A &= -a^2 : b^2 : c^2, \\ K_B &= a^2 : -b^2 : c^2, \\ K_C &= a^2 : b^2 : -c^2. \end{aligned}$$

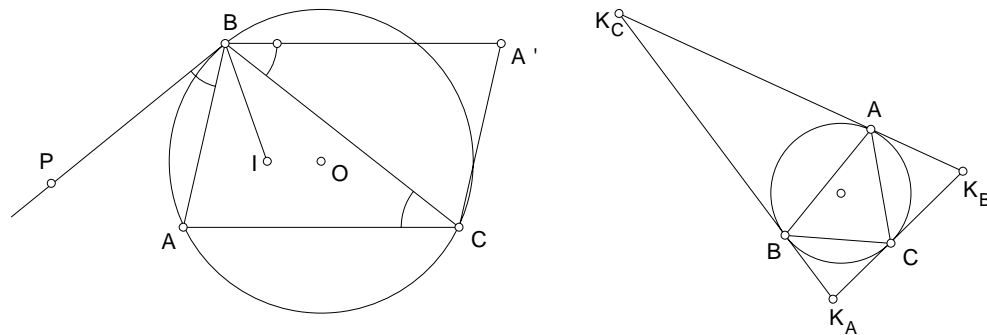

Exercise

1. What is the isogonal conjugate of the incenter I ?
2. Given λ, μ, ν , there is a (unique) point P such that

$$PP_1 : PP_2 : PP_3 = \lambda : \mu : \nu$$

if and only if each “nontrivial” sum of $a\lambda, b\mu$ and $c\nu$ is nonzero. This is the point

$$\frac{a\lambda}{a\lambda + b\mu + c\nu}A + \frac{b\mu}{a\lambda + b\mu + c\nu}B + \frac{c\nu}{a\lambda + b\mu + c\nu}C.$$

3. Given a triangle ABC , show that its tangential triangle is finite unless ABC contains a right angle.

(a) The angles of the tangential triangle are $180^\circ - 2\alpha$, $180^\circ - 2\beta$, and $180^\circ - 2\gamma$, (or 2α , 2β and $2\gamma - 180^\circ$ if the angle at C is obtuse).

(b) The sides of the tangential triangle are in the ratio

$$\sin 2\alpha : \sin 2\beta : \sin 2\gamma = a^2(b^2+c^2-a^2) : b^2(c^2+a^2-b^2) : c^2(a^2+b^2-c^2).$$

4. Justify the following table for the homogeneous coordinates of points associated with a triangle.

Point	Symbol	Homogeneous coordinates
Centroid	G	1:1:1
Incenter	I	a : b : c
Excenters	I_A	-a : b : c
	I_B	a : -b : c
	I_C	a : b : -c
Gergonne point	L	$(s-b)(s-c) : (s-c)(s-a) : (s-a)(s-b)$
Nagel point	N	$s-a : s-b : s-c$
Symmedian point	K	$a^2 : b^2 : c^2$
Exsymmedian points	K_A	$-a^2 : b^2 : c^2$
	K_B	$a^2 : -b^2 : c^2$
	K_C	$a^2 : b^2 : -c^2$
Circumcenter	O	$a^2(b^2+c^2-a^2) : b^2(c^2+a^2-b^2) : c^2(a^2+b^2-c^2)$
Orthocenter	H	$(a^2+b^2-c^2)(c^2+a^2-b^2) : (b^2+c^2-a^2)(a^2+b^2-c^2) : (c^2+a^2-b^2)(b^2+c^2-a^2)$

5. Show that the incenter I , the centroid G , and the Nagel point N are collinear. Furthermore, $IG : GN = 1 : 2$.

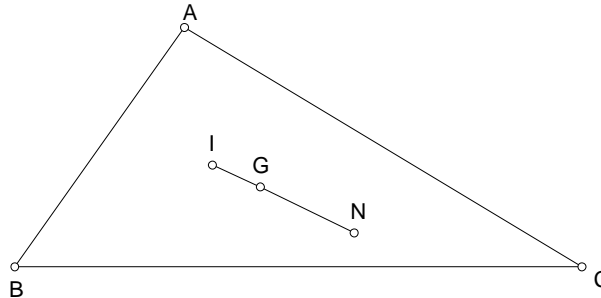

$$IG : GN = 1 : 2.$$

6. Find the barycentric coordinates of the incenter of $\triangle O_1O_2O_3$.⁷

⁷Solution. $\frac{1}{4s}[(b+c)A + (c+a)B + (a+b)C] = \frac{3}{2}M - \frac{1}{2}I$.

7. The Gergonne point of the triangle $K_A K_B K_C$ is the symmedian point K of $\triangle ABC$.
8. Characterize the triangles of which the midpoints of the altitudes are collinear. ⁸
9. Show that the mirror image of the orthocenter H in a side of a triangle lies on the circumcircle.
10. Let P be a point in the plane of $\triangle ABC$, G_A, G_B, G_C respectively the centroids of $\triangle PBC, \triangle PCA$ and $\triangle PAB$. Show that AG_A, BG_B , and CG_C are concurrent. ⁹
11. If the sides of a triangle are in arithmetic progression, then the line joining the centroid to the incenter is parallel to a side of the triangle.
12. If the squares of a triangle are in arithmetic progression, then the line joining the centroid and the symmedian point is parallel to a side of the triangle.

8.6.8

In §? we have established, using the trigonometric version of Ceva theorem, the concurrency of the lines joining each vertex of a triangle to the point of contact of the circumcircle with the mixtilinear incircle in that angle. Suppose the line AA', BB', CC' intersects the sides BC, CA, AB at points X, Y, Z respectively. We have

$$\frac{BX}{XC} = \frac{c}{b} \cdot \frac{\sin \alpha_1}{\sin \alpha_2} = \frac{(s-b)/b^2}{(s-c)/c^2}.$$

$$\begin{array}{l} BX : XC = \frac{s-b}{b^2} : \frac{s-c}{c^2}, \\ AY : YC = \frac{s-c}{a^2} : \frac{s-c}{c^2}, \\ AZ : ZB = \frac{s-c}{a^2} : \frac{s-b}{b^2}. \end{array}$$

⁸More generally, if P is a point with nonzero homogeneous coordinates with respect to $\triangle ABC$, and AP, BP, CP cut the opposite sides at X, Y and Z respectively, then the midpoints of AX, BY, CZ are never collinear. It follows that the orthocenter must be a vertex of the triangle, and the triangle must be right. See MG1197.844.S854.

⁹At the centroid of A, B, C, P ; see MGQ781.914.

These cevians therefore intersect at the point with homogeneous coordinates

$$\frac{a^2}{s-a} : \frac{b^2}{s-b} : \frac{c^2}{s-c}.$$

This is the isogonal conjugate of the point with homogeneous coordinates $s-a : s-b : s-c$, the Nagel point.

8.6.9

The isogonal conjugate of the Nagel point is the external center of similitude of the circumcircle and the incircle.

Exercise

1. Show that the isogonal conjugate of the Gergonne point is the internal center of similitude of the circumcircle and the incircle.

8.7 Point with equal parallel intercepts

Given a triangle ABC , we locate the point P through which the parallels to the sides of ABC make equal intercepts by the lines containing the sides of ABC .¹⁰ It is easy to see that these intercepts have lengths $(1-x)a$, $(1-y)b$, and $(1-z)c$ respectively. For the equal - parallel - intercept point P ,

$$1-x : 1-y : 1-z = \frac{1}{a} : \frac{1}{b} : \frac{1}{c}.$$

Note that

$$(1-x)A + (1-y)B + (1-z)C = 3G - 2P.$$

This means that $3G - P = 2I'$, the isotomic conjugate of the incenter I . From this, the points I' , G , P are collinear and

$$I'G : GP = 1 : 2.$$

¹⁰AMM E396. D.L. MacKay - C.C. Oursler.

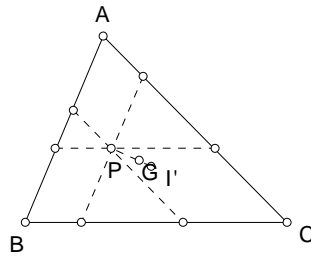

Exercise

1. Show that the triangles OII' and HNP are homothetic at the centroid G .¹¹
2. Let P be a point with homogeneous coordinates $x : y : z$. Suppose the parallel through P to BC intersects AC at Y and AB at Z . Find the homogeneous coordinates of the points Y and Z , and the length of the segment YZ .¹²

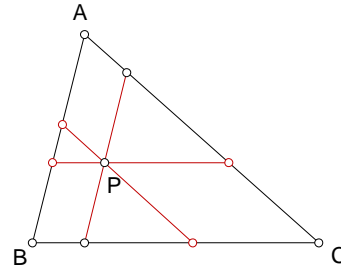
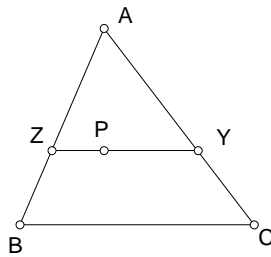

3. Make use of this to determine the homogeneous coordinates of the equal - parallel - intercept point¹³ of triangle ABC and show that the equal parallel intercepts have a common length

$$= \frac{2abc}{ab + bc + ca}.$$

4. Let K be a point with homogeneous coordinates $p : q : r$ with respect to triangle ABC , X, Y, Z the traces of K on the sides of the triangle.

¹¹The centroid G divides each of the segments OH , IN , and $I'P$ in the ratio $1 : 2$.

¹² Y and Z are respectively the points $x : 0 : y + z$ and $x : y + z : 0$. The segment YZ has length $\frac{a(y+z)}{x+y+z}$.

¹³ $x : y : z = -\frac{1}{a} + \frac{1}{b} + \frac{1}{c} : \frac{1}{a} - \frac{1}{b} + \frac{1}{c} : \frac{1}{a} + \frac{1}{b} - \frac{1}{c}$.

If the triangle ABC is completed into parallelograms $ABA'C$, $BCB'A$, and $CAC'B$, then the lines $A'X$, $B'Y$, and $C'Z$ are concurrent at the point Q with homogeneous coordinates ¹⁴

$$-\frac{1}{p} + \frac{1}{q} + \frac{1}{r} : \frac{1}{p} - \frac{1}{q} + \frac{1}{r} : \frac{1}{p} + \frac{1}{q} - \frac{1}{r}.$$

¹⁴The trace of K on the line BC is the point X with homogeneous coordinates $0 : q : r$. If the triangle ABC is completed into a parallelogram $ABA'C$, the fourth vertex A' is the point $-1 : 1 : 1$. The line $A'X$ has equation $(q - r)x - ry + qz = 0$; similarly for the lines $B'Y$ and $C'Z$. From this it is straightforward to verify that these three lines are concurrent at the given point.

8.8 Area formula

If P , Q and R are respectively the points

$$P = x_1A + y_1B + z_1C, \quad Q = x_2A + y_2B + z_2C, \quad R = x_3A + y_3B + z_3C,$$

then the area of triangle PQR is given by

$$\Delta PQR = \begin{vmatrix} x_1 & y_1 & z_1 \\ x_2 & y_2 & z_2 \\ x_3 & y_3 & z_3 \end{vmatrix} \Delta.$$

Exercise

- Let X , Y , and Z be points on BC , CA , and AB respectively such that

$$BX : XC = \lambda : \lambda', \quad CY : YA = \mu : \mu', \quad AZ : ZB = \nu : \nu'.$$

The area of triangle XYZ is given by ¹⁵

$$\Delta XYZ = \frac{\lambda\mu\nu + \lambda'\mu'\nu'}{(\lambda + \lambda')(\mu + \mu')(\nu + \nu')}.$$

- Deduce that the points X , Y , Z are collinear if and only if $\lambda\mu\nu = -\lambda'\mu'\nu'$.
- If X' , Y' , Z' are isotomic conjugates of X , Y , Z on their respective sides, show that the areas of the triangles XYZ and $X'Y'Z'$ are equal.

¹⁵Proof. These have barycentric coordinates

$$X = \frac{\lambda'}{\lambda + \lambda'}B + \frac{\lambda}{\lambda + \lambda'}C, \quad Y = \frac{\mu'}{\mu + \mu'}C + \frac{\mu}{\mu + \mu'}A, \quad Z = \frac{\nu'}{\nu + \nu'}A + \frac{\nu}{\nu + \nu'}B.$$

By the preceding exercise,

$$\begin{aligned} \Delta XYZ &= \frac{1}{(\lambda + \lambda')(\mu + \mu')(\nu + \nu')} \begin{vmatrix} 0 & \lambda' & \lambda \\ \mu & 0 & \mu' \\ \nu & \nu & 0 \end{vmatrix} \\ &= \frac{\lambda\mu\nu + \lambda'\mu'\nu'}{(\lambda + \lambda')(\mu + \mu')(\nu + \nu')}. \end{aligned}$$

8.9 Routh's Theorem

8.9.1 Intersection of two cevians

Let Y and Z be points on the lines CA and AB respectively such that $CY : YA = \mu : \mu'$ and $AZ : ZB = \nu : \nu'$. The lines BY and CZ intersect at the point P with homogeneous coordinates $\mu\nu' : \mu\nu : \mu'\nu'$:

$$P = \frac{1}{\mu\nu + \mu'\nu' + \mu\nu'}(\mu\nu'A + \mu\nu B + \mu'\nu'C).$$

8.9.2 Theorem

Let X , Y and Z be points on the lines BC , CA and AB respectively such that

$$BX : XC = \lambda : \lambda', \quad CY : YA = \mu : \mu', \quad AZ : ZB = \nu : \nu'.$$

The lines AX , BY and CZ bound a triangle of area

$$\frac{(\lambda\mu\nu - \lambda'\mu'\nu')^2}{(\lambda\mu + \lambda'\mu' + \lambda\mu')(\mu\nu + \mu'\nu' + \mu\nu')(\nu\lambda + \nu'\lambda' + \nu\lambda')} \Delta.$$

Exercise

- In each of the following cases, $BX : XC = \lambda : 1$, $CY : YA = \mu : 1$, and $AZ : ZB = \nu : 1$. Find $\frac{\Delta'}{\Delta}$.

λ	μ	ν	$\lambda\mu\nu - 1$	$\lambda\mu + \lambda + 1$	$\mu\nu + \mu + 1$	$\nu\lambda + \nu + 1$	$\frac{\Delta'}{\Delta}$
1	1	2					
1	1	4					
1	2	3					
1	4	7					
2	2	2					
3	6	7					

- The cevians AX , BY , CZ are such that $BX : XC = CY : YA = AZ : ZB = \lambda : 1$. Find λ such that the area of the triangle intercepted by the three cevians AX , BY , CZ is $\frac{1}{7}$ of ΔABC .

3. The cevians AD , BE , CF intersect at P . Show that ¹⁶

$$\frac{[DEF]}{[ABC]} = 2 \frac{PD}{PA} \cdot \frac{PE}{PB} \cdot \frac{PF}{PC}.$$

4. The cevians AD , BE , and CF of triangle ABC intersect at P . If the areas of the triangles BDP , CEP , and AFP are equal, show that P is the centroid of triangle ABC .

8.10 Distance formula in barycentric coordinates

8.10.1 Theorem

The distance between two points $P = xA + yB + zC$ and $Q = uA + vB + wC$ is given by

$$PQ^2 = \frac{1}{2}[(x-u)^2(b^2+c^2-a^2) + (y-v)^2(c^2+a^2-b^2) + (z-w)^2(a^2+b^2-c^2)].$$

Proof. It is enough to assume $Q = C$. The distances from P to the sides BC and CA are respectively $PP_1 = 2\Delta \cdot \frac{x}{a}$ and $PP_2 = 2\Delta \cdot \frac{y}{b}$. By the cosine formula,

$$\begin{aligned} P_1P_2^2 &= PP_1^2 + PP_2^2 + 2 \cdot PP_1 \cdot PP_2 \cdot \cos \gamma \\ &= 4\Delta^2 \left[\left(\frac{x}{a}\right)^2 + \left(\frac{y}{b}\right)^2 + xy \cdot \frac{a^2 + b^2 - c^2}{a^2b^2} \right] \\ &= 4\Delta^2 \left\{ \left(\frac{x}{a}\right)^2 + \left(\frac{y}{b}\right)^2 + \frac{1}{2}[(1-z)^2 - x^2 - y^2] \cdot (a^2 + b^2 - c^2) \right\} \\ &= \frac{2\Delta^2}{a^2b^2} [x^2(b^2 + c^2 - a^2) + y^2(c^2 + a^2 - b^2) + (z-1)^2(a^2 + b^2 - c^2)]. \end{aligned}$$

It follows that $CP = \frac{P_1P_2}{\sin \gamma} = \frac{ab \cdot P_1P_2}{2\Delta}$ is given by

$$CP^2 = \frac{1}{2} [x^2(b^2 + c^2 - a^2) + y^2(c^2 + a^2 - b^2) + (z-1)^2(a^2 + b^2 - c^2)].$$

The general formula follows by replacing x , y , $z-1$ by $x-u$, $y-v$, $z-w$ respectively.

¹⁶Cruze 2161.

Chapter 9

Circles inscribed in a triangle

9.1

Given a triangle ABC , to locate a point P on the side BC so that the incircles of triangles ABP and ACP have equal radii.

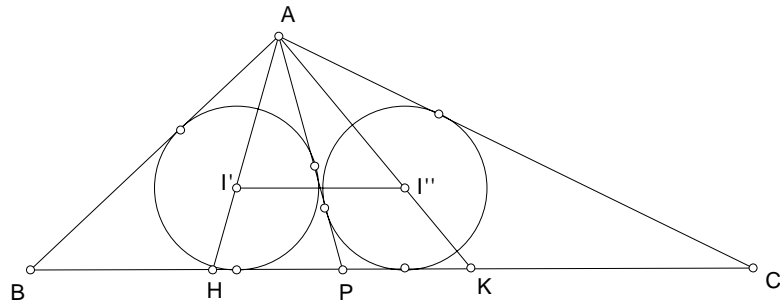

9.1.1 Analysis

Suppose $BP : PC = k : 1 - k$, and denote the length of AP by x . By Stewart's Theorem,

$$x^2 = kb^2 + (1 - k)c^2 - k(1 - k)a^2.$$

Equating the inradii of the triangles ABP and ACP , we have

$$\frac{2k\Delta}{c + x + ka} = \frac{2(1 - k)\Delta}{b + x + (1 - k)a}.$$

This latter equation can be rewritten as

$$\frac{c+x+ka}{k} = \frac{b+x+(1-k)a}{1-k}, \quad (9.1)$$

or

$$\frac{c+x}{k} = \frac{b+x}{1-k}, \quad (9.2)$$

from which

$$k = \frac{x+c}{2x+b+c}.$$

Now substitution into (1) gives

$$x^2(2x+b+c)^2 = (2x+b+c)[(x+c)b^2 + (x+b)c^2] - (x+b)(x+c)a^2.$$

Rearranging, we have

$$\begin{aligned} (x+b)(x+c)a^2 &= (2x+b+c)[(x+c)b^2 + (x+b)c^2 - x^2[(x+b) + (x+c)]] \\ &= (2x+b+c)[(x+b)(c^2 - x^2) + (x+c)(b^2 - x^2)] \\ &= (2x+b+c)(x+b)(x+c)[(c-x) + (b-x)] \\ &= (2x+b+c)(x+b)(x+c)[(b+c) - 2x] \\ &= (x+b)(x+c)[(b+c)^2 - 4x^2]. \end{aligned}$$

From this,

$$x^2 = \frac{1}{4}((b+c)^2 - a^2) = \frac{1}{4}(b+c+a)(b+c-a) = s(s-a).$$

9.1.2

Lau¹ has proved an interesting formula which leads to a simple construction of the point P . If the angle between the median AD and the angle bisector AX is θ , then

$$m_a \cdot w_a \cdot \cos \theta = s(s-a).$$

¹Solution to Crux 1097.

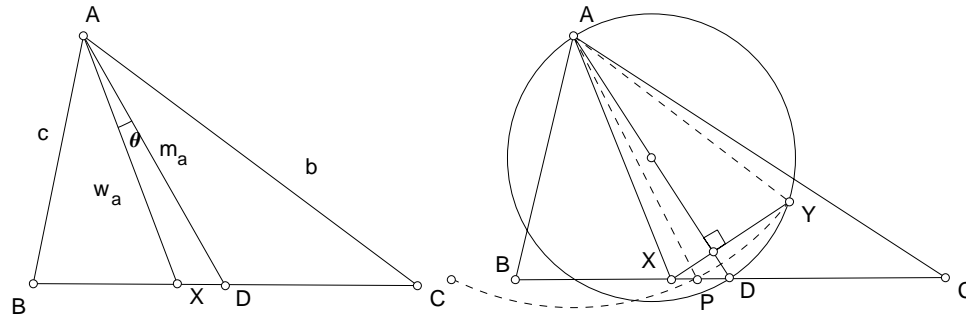

This means if the perpendicular from X to AD is extended to intersect the circle with diameter AD at a point Y , then $AY = \sqrt{s(s-a)}$. Now, the circle $A(Y)$ intersects the side BC at two points, one of which is the required point P .

9.1.3 An alternative construction of the point P

Let X and Y be the projections of the incenter I and the excenter I_A on the side AB . Construct the circle with XY as diameter, and then the tangents from A to this circle. P is the point on BC such that AP has the same length as these tangents.

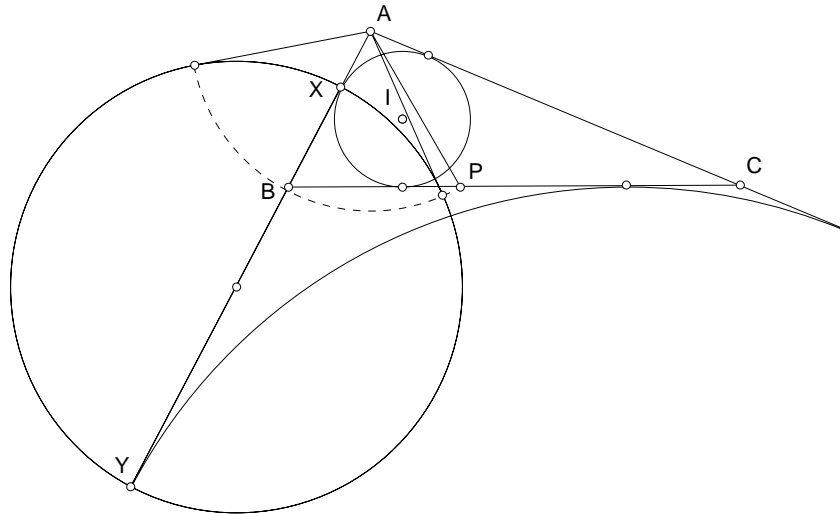

Exercise

1. Show that

$$r' = \frac{s - \sqrt{s(s-a)}}{a} \cdot r.$$

2. Show that the circle with XY as diameter intersects BC at P if and only if $\triangle ABC$ is isosceles. ²

9.1.4 Proof of Lau's formula

Let θ be the angle between the median and the bisector of angle A .

Complete the triangle ABC into a parallelogram $ABA'C$. In triangle $AA'C$, we have

$$\begin{aligned} AA' &= 2m_a, & AC &= b, & A'C &= c; \\ \angle ACA' &= 180^\circ - \alpha, & \angle AA'C &= \frac{\alpha}{2} + \theta, & \angle A'AC &= \frac{\alpha}{2} - \theta. \end{aligned}$$

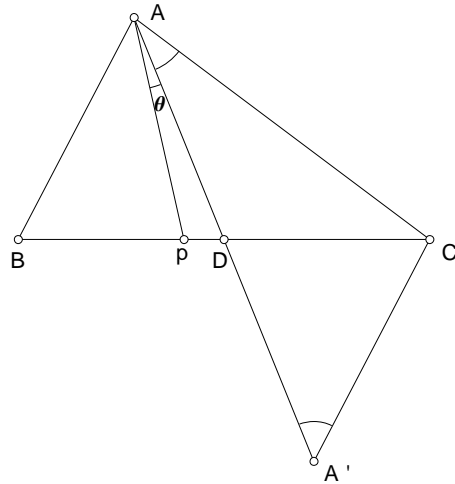

By the sine formula,

$$\frac{b+c}{2m_a} = \frac{\sin(\frac{\alpha}{2} + \theta) + \sin(\frac{\alpha}{2} - \theta)}{\sin(180^\circ - \alpha)} = \frac{2 \sin \frac{\alpha}{2} \cos \theta}{\sin \alpha} = \frac{\cos \theta}{\cos \frac{\alpha}{2}}.$$

From this it follows that

$$m_a \cdot \cos \theta = \frac{b+c}{2} \cdot \cos \frac{\alpha}{2}.$$

²Hint: AP is tangent to the circle $XY P$.

Now, since $w_a = \frac{2bc}{b+c} \cos \frac{\alpha}{2}$, we have

$$m_a \cdot w_a \cdot \cos \theta = bc \cos^2 \frac{\alpha}{2} = s(s-a).$$

This proves Lau's formula.

9.1.5

Here, we make an interesting observation which leads to a simpler construction of P , bypassing the calculations, and leading to a stronger result: (3) remains valid if instead of inradii, we equate the exradii of the same two subtriangles on the sides BP and CP . Thus, the two subtriangles have equal inradii if and only if they have equal exradii on the sides BP and CP .

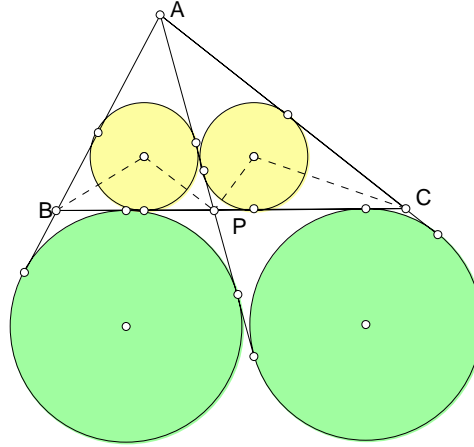

Let $\theta = \angle APB$ so that $\angle APC = 180^\circ - \theta$. If we denote the inradii by r' and the exradii by ρ , then

$$\frac{r'}{\rho} = \tan \frac{\beta}{2} \tan \frac{\theta}{2} = \tan(90^\circ - \frac{\theta}{2}) \tan \frac{\gamma}{2}.$$

Since $\tan \frac{\theta}{2} \tan(90^\circ - \frac{\theta}{2}) = 1$, we also have

$$\left(\frac{r'}{\rho}\right)^2 = \tan \frac{\beta}{2} \tan \frac{\gamma}{2}.$$

This in turn leads to

$$\tan \frac{\theta}{2} = \sqrt{\frac{\tan \frac{\gamma}{2}}{\tan \frac{\beta}{2}}}.$$

In terms of the sides of triangle ABC , we have

$$\tan \frac{\theta}{2} = \sqrt{\frac{s-b}{s-c}} = \frac{\sqrt{(s-b)(s-c)}}{s-c} = \frac{\sqrt{BX \cdot XC}}{XC}.$$

This leads to the following construction of the point P .

Let the incircle of $\triangle ABC$ touch the side BC at X .

Construct a semicircle with BC as diameter to intersect the perpendicular to BC through X at Y .

Mark a point Q on the line BC such that $AQ \parallel YC$.

The intersection of the perpendicular bisector of AQ with the side BC is the point P required.

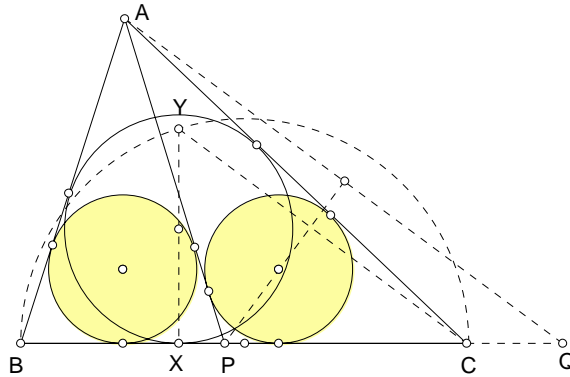

Exercise

- Let ABC be an isosceles triangle with $AB = BC$. F is the midpoint of AB , and the side BA is extended to a point K with $AK = \frac{1}{2}AC$. The perpendicular through A to AB intersects the circle $F(K)$ at a point Q . P is the point on BC (the one closer to B if there are two) such that $AP = AQ$. Show that the inradii of triangles ABP and ACP are equal.

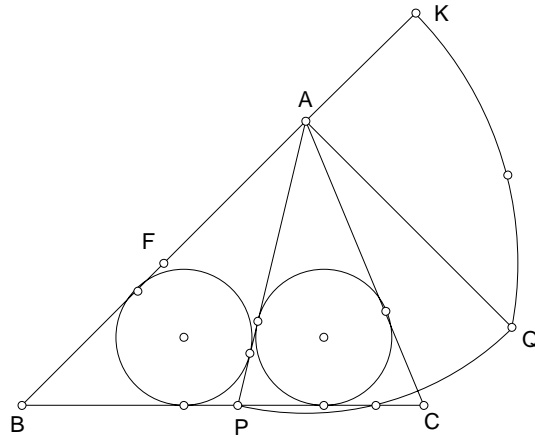

2. Given triangle ABC , let $P_0, P_1, P_2, \dots, P_n$ be points on BC such that $P_0 = B, P_n = C$ and the inradii of the subtriangles $AP_{k-1}P_k$, $k = 1, \dots, n$, are all equal. For $k = 1, 2, \dots, n$, denote $\angle AP_kP_{k-1} = \theta_k$. Show that $\tan \frac{\theta_k}{2}$, $k = 1, \dots, n-1$ are $n-1$ geometric means between $\cot \frac{\beta}{2}$ and $\tan \frac{\gamma}{2}$, i.e.,

$$\frac{1}{\tan \frac{\beta}{2}}, \tan \frac{\theta_1}{2}, \tan \frac{\theta_2}{2}, \dots, \tan \frac{\theta_{n-1}}{2}, \tan \frac{\gamma}{2}$$

form a geometric progression.

3. Let P be a point on the side BC of triangle ABC such that the excircle of triangle ABP on the side BP and the incircle of triangle ACP have the same radius. Show that ³

$$BP : PC = -a + b + 3c : a + 3b + c,$$

and

$$AP = \frac{(b+c)^2 - a(s-c)}{2(b+c)}.$$

³If $BP : PC = k : 1 - k$, and $AP = x$, then

$$\frac{k}{c+x-ka} = \frac{(1-k)}{b+x+(1-k)a}.$$

Also, by Stewart's Theorem $x^2 = kb^2 + (1-k)c^2 - k(1-k)a^2$.

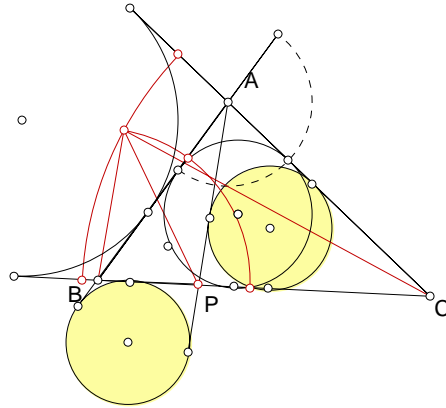

4. Let ABC be an isosceles triangle, D the midpoint of the base BC . On the minor arc BC of the circle $A(B)$, mark a point X such that $CX = CD$. Let Y be the projection of X on the side AC . Let P be a point on BC such that $AP = AY$. Show that the inradius of triangle ABP is equal to the exradius of triangle ACP on the side CP .

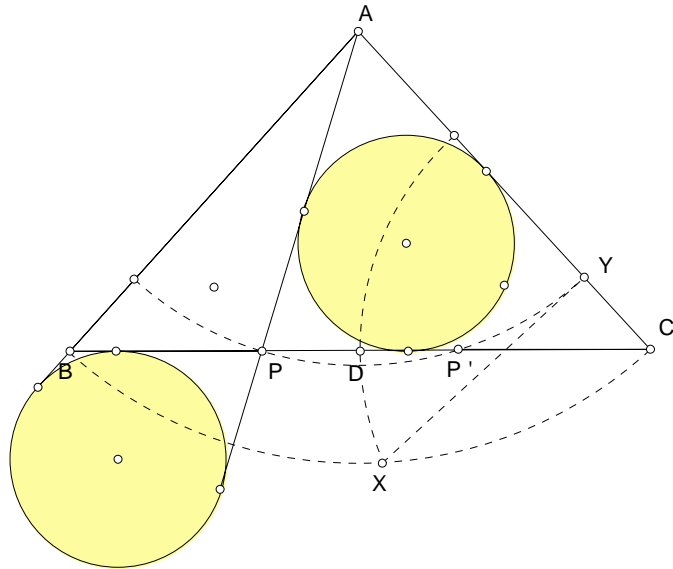

9.2

Given a triangle, to construct three circles through a common point, each tangent to two sides of the triangle, such that the 6 points of contact are concyclic.

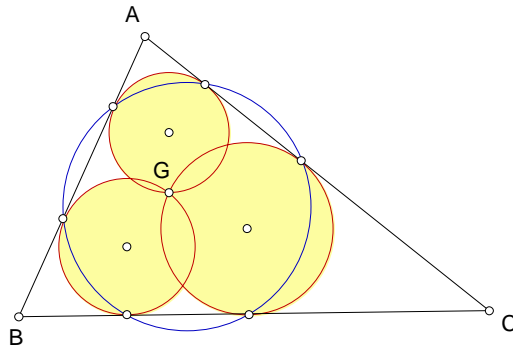

Let G be the common point of the circles, and X_2, X_3 on the side BC , Y_1, Y_3 on CA , and Z_1, Z_2 on AB , the points of contact.

9.2.1 Analysis ⁴

Consider the circle through the 6 points of contact. The line joining the center to each vertex is the bisector of the angle at that vertex. This center is indeed the incenter I of the triangle. It follows that the segments X_2X_3 , Y_3Y_1 , and Z_1Z_2 are all equal in length. Denote by X, Y, Z the projections of I on the sides. Then $XX_2 = XX_3$. Also,

$$AZ_2 = AZ_1 + Z_1Z_2 = AY_1 + Y_1Y_3 = AY_3.$$

This means that X and A are both on the radical axis of the circles (K_2) and (K_3) . The line AX is the radical axis. Similarly, the line $\frac{BY}{CZ}$ is the radical axis of the pair of circles $\left(\begin{matrix} (K_3) & (K_1) \\ (K_1) & (K_2) \end{matrix} \right)$. The common point G of the circles, being the intersection of AX , BY , and CZ , is the Gergonne point of the triangle.

⁴Thébault - Eves, AMM E457.

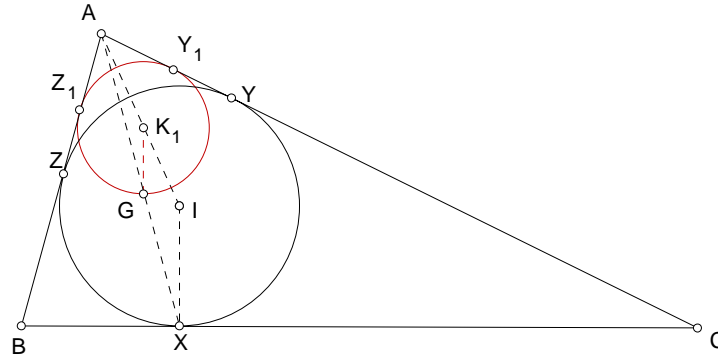

The center K_1 is the intersection of the segment AI and the parallel through G to the radius XI of the incircle.

The other two centers K_2 and K_3 can be similarly located.

9.3

Given a triangle, to construct three congruent circles through a common point, each tangent to two sides of the triangle.

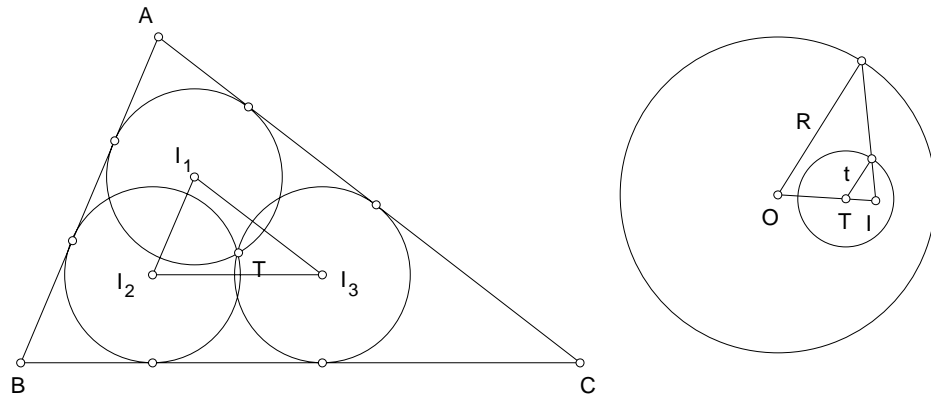

9.3.1 Analysis

Let I_1, I_2, I_3 be the centers of the circles lying on the bisectors IA, IB, IC respectively. Note that the lines I_2I_3 and BC are parallel; so are the pairs I_3I_1, CA , and I_1I_2, AB . It follows that triangles $I_1I_2I_3$ and ABC are per-

spective from their common incenter I . The line joining their circumcenters passes through I . Note that T is the circumcenter of triangle $I_1I_2I_3$, the circumradius being the common radius t of the three circles. This means that T , O and I are collinear. Since

$$\frac{I_3I_1}{CA} = \frac{I_1I_2}{AB} = \frac{I_2I_3}{BC} = \frac{r-t}{r},$$

we have $t = \frac{r-t}{r} \cdot R$, or

$$\frac{t}{R} = \frac{r}{R+r}.$$

This means I divides the segment OT in the ratio

$$TI : IO = -r : R + r.$$

Equivalently, $OT : TI = R : r$, and T is the internal center of similitude of the circumcircle and the incircle.

9.3.2 Construction

Let O and I be the circumcenter and the incenter of triangle ABC .

- (1) Construct the perpendicular from I to BC , intersecting the latter at X .
- (2) Construct the perpendicular from O to BC , intersecting the circumcircle at M (so that IX and OM are directly parallel).
- (3) Join OX and IM . Through their intersection P draw a line parallel to IX , intersecting OI at T , the internal center of similitude of the circumcircle and incircle.
- (4) Construct the circle $T(P)$ to intersect the segments IA , IB , IC at I_1 , I_2 , I_3 respectively.
- (5) The circles $I_j(T)$, $j = 1, 2, 3$ are three equal circles through T each tangent to two sides of the triangle.

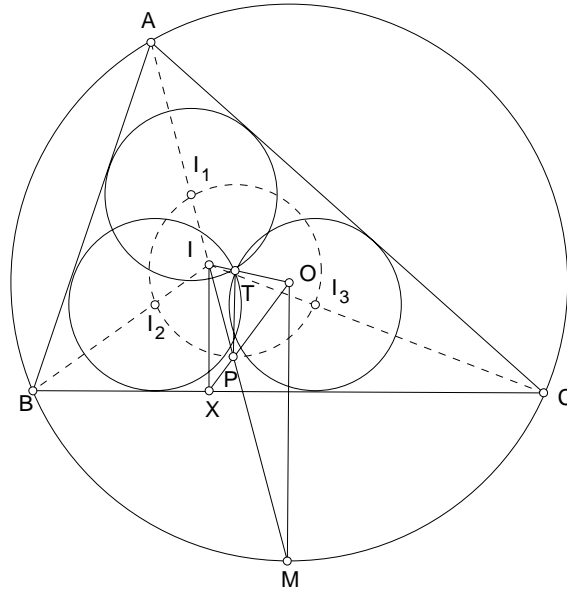

9.4

9.4.1 Proposition

Let I be the incenter of $\triangle ABC$, and I_1, I_2, I_3 the incenters of the triangles $IBC, ICA,$ and IAB respectively. Extend II_1 beyond I_1 to intersect BC at A' , and similarly II_2 beyond I_2 to intersect CA at B' , II_3 beyond I_3 to intersect AB at C' . Then, the lines AA', BB', CC' are concurrent at a point ⁵ with homogeneous barycentric coordinates

$$a \sec \frac{\alpha}{2} : b \sec \frac{\beta}{2} : c \sec \frac{\gamma}{2}.$$

Proof. The angles of triangle IBC are

$$\pi - \frac{1}{2}(\beta + \gamma), \quad \frac{\beta}{2}, \quad \frac{\gamma}{2}.$$

The homogeneous coordinates of I_1 with respect to IBC are

$$\cos \frac{\alpha}{2} : \sin \frac{\beta}{2} : \sin \frac{\gamma}{2}.$$

⁵This point apparently does not appear in Kimberling's list.

Since $I = \frac{1}{2s}(a \cdot A + b \cdot B + c \cdot C)$, the homogeneous coordinates of I_1 with respect to ABC are

$$\begin{aligned} & a \cos \frac{\alpha}{2} : b \cos \frac{\alpha}{2} + 2s \sin \frac{\beta}{2} : c \cos \frac{\alpha}{2} + 2s \sin \frac{\gamma}{2} \\ &= a : b(1 + 2 \cos \frac{\gamma}{2}) : c(1 + 2 \cos \frac{\beta}{2}). \end{aligned}$$

Here, we have made use of the sine formula:

$$\frac{a}{\sin \alpha} = \frac{b}{\sin \beta} = \frac{c}{\sin \gamma} = \frac{2s}{\sin \alpha + \sin \beta + \sin \gamma} = \frac{2s}{4 \cos \frac{\alpha}{2} \cos \frac{\beta}{2} \cos \frac{\gamma}{2}}.$$

Since I has homogeneous coordinates $a : b : c$, it is easy to see that the line II_1 intersects BC at the point A' with homogeneous coordinates

$$0 : b \cos \frac{\gamma}{2} : c \cos \frac{\beta}{2} = 0 : b \sec \frac{\beta}{2} : c \sec \frac{\gamma}{2}.$$

Similarly, B' and C' have coordinates

$$\begin{aligned} A' & 0 : b \sec \frac{\beta}{2} : c \sec \frac{\gamma}{2}, \\ B' & a \sec \frac{\alpha}{2} : 0 : c \sec \frac{\gamma}{2}, \\ C' & a \sec \frac{\alpha}{2} : b \sec \frac{\beta}{2} : 0. \end{aligned}$$

From these, it is clear that AA' , BB' , CC' intersect at a point with homogeneous coordinates

$$a \sec \frac{\alpha}{2} : b \sec \frac{\beta}{2} : c \sec \frac{\gamma}{2}.$$

Exercise

1. Let O_1 , O_2 , O_3 be the circumcenters of triangles I_1BC , I_2CA , I_3AB respectively. Are the lines O_1I_1 , O_2I_2 , O_3I_3 concurrent?

9.5 Malfatti circles

9.5.1 Construction Problem

Given a triangle, to construct three circles mutually tangent to each other, each touching two sides of the triangle.

Construction

Let I be the incenter of triangle ABC .

- (1) Construct the incircles of the subtriangles IBC , ICA , and IAB .
- (2) Construct the external common tangents of each pair of these incircles. (The incircles of ICA and IAB have IA as a common tangent. Label the other common tangent Y_1Z_1 with Y_1 on CA and Z_1 on AB respectively. Likewise the common tangent of the incircles of IAB and IBC is Z_2X_2 with Z_2 on AB and X_2 on BC , and that of the incircles of IBC and ICA is X_3Y_3 with X_3 on BC and Y_3 on CA .) These common tangents intersect at a point P .
- (3) The incircles of triangles AY_1Z_1 , BZ_2X_2 , and CX_3Y_3 are the required Malfatti circles.

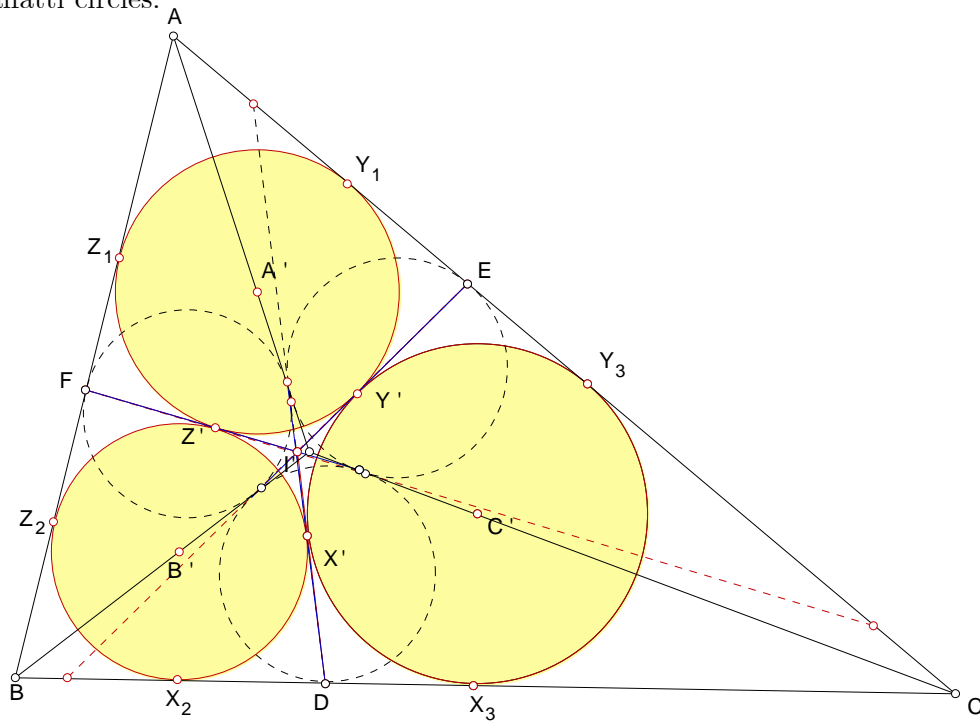

Exercise

1. Three circles of radii r_1 , r_2 , r_3 are mutually tangent to each other. Find the lengths of the sides of the triangle bounded by their external

common tangents. ⁶

9.6

9.6.1

Given a circle $K(a)$ tangent to $O(R)$ at A , and a point B , to construct a circle $K'(b)$ tangent externally to $K(a)$ and internally to $O(R)$ at B .

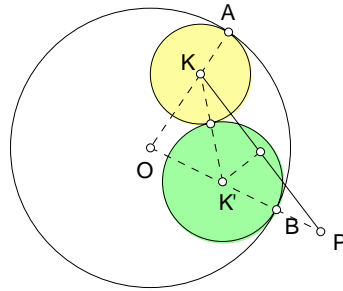

Construction

Extend OB to P such that $BP = a$. Construct the perpendicular bisector of KP to intersect OB at K' , the center of the required circle.

9.6.2

Two circles $H(a)$ and $K(b)$ are tangent externally to each other, and internally to a third, larger circle $O(R)$, at A and B respectively.

$$AB = 2R \sqrt{\frac{a}{R-a} \cdot \frac{b}{R-b}}$$

⁶Cruze 618.

$$a = \frac{r}{r-r_2}(\sqrt{r_2 r_3} - \sqrt{r_3 r_1} + \sqrt{r_1 r_2}) + \frac{r}{r-r_3}(\sqrt{r_2 r_3} + \sqrt{r_3 r_1} - \sqrt{r_1 r_2})$$

where

$$r = \frac{\sqrt{r_1} + \sqrt{r_2} + \sqrt{r_3} + \sqrt{r_1 + r_2 + r_3}}{\sqrt{r_2 r_3} + \sqrt{r_3 r_1} + \sqrt{r_1 r_2}} \cdot \sqrt{r_1 r_2 r_3}.$$

Proof. Let $\angle AOB = \theta$. Applying the cosine formula to triangle AOB ,

$$AB^2 = R^2 + R^2 - 2R^2 \cos \theta,$$

where

$$\cos \theta = \frac{(R-a)^2 + (R-b)^2 - (a+b)^2}{2(R-a)(R-b)},$$

by applying the cosine formula again, to triangle OHK .

Exercise

1. Given a circle $K(A)$ tangent externally to $O(A)$, and a point B on $O(A)$, construct a circle tangent to $O(A)$ at B and to $K(A)$ externally (respectively internally).
2. Two circles $H(a)$ and $K(b)$ are tangent externally to each other, and also externally to a third, larger circle $O(R)$, at A and B respectively. Show that

$$AB = 2R \sqrt{\frac{a}{R+a} \cdot \frac{b}{R+b}}.$$

9.6.3

Let $H(a)$ and $K(b)$ be two circles tangent internally to $O(R)$ at A and B respectively. If (P) is a circle tangent internally to (O) at C , and externally to each of (H) and (K) , then

$$AC : BC = \sqrt{\frac{a}{R-a}} : \sqrt{\frac{b}{R-b}}.$$

Proof. The lengths of AC and BC are given by

$$AC = 2R \sqrt{\frac{ac}{(R-a)(R-c)}}, \quad BC = 2R \sqrt{\frac{bc}{(R-b)(R-c)}}.$$

Construction of the point C

(1) On the segment AB mark a point X such that the cevians AK , BH , and OX intersect. By Ceva theorem,

$$AX : XB = \frac{a}{R-a} : \frac{b}{R-b}.$$

(2) Construct a circle with AB as diameter. Let the perpendicular through X to AB intersect this circle at Q and Q' . Let the bisectors angle AQB intersect the line AB at Y .

Note that $AQ^2 = AX \cdot AB$ and $BQ^2 = XB \cdot AB$. Also, $AY : YB = AQ : QB$. It follows that

$$AY : YB = \sqrt{\frac{a}{R-a}} : \sqrt{\frac{b}{R-b}}$$

(3) Construct the circle through Q, Y, Q' to intersect (O) at C and C' .

Then C and C' are the points of contact of the circles with (O) , (H) , and (K) . Their centers can be located by the method above.

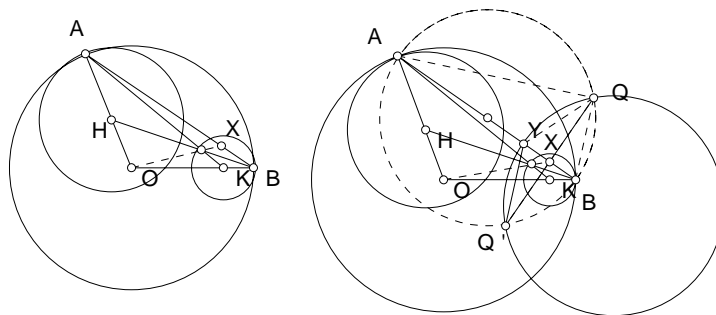

9.6.4

Given three points A, B, C on a circle (O) , to locate a point D such that there is a chain of 4 circles tangent to (O) internally at the points A, B, C, D .

Bisect angle ABC to intersect AC at E and the circle (O) at X . Let Y be the point diametrically opposite to X . The required point D is the intersection of the line YE and the circle (O) .

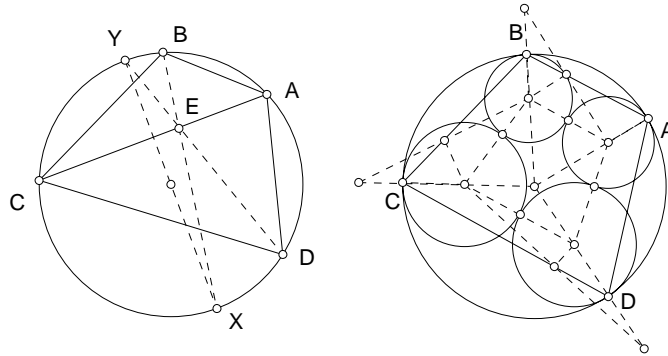

Beginning with any circle $K(A)$ tangent internally to $O(A)$, a chain of four circles can be completed to touch (O) at each of the four points A, B, C, D .

Exercise

- Let A, B, C, D, E, F be six consecutive points on a circle. Show that the chords AD, BE, CF are concurrent if and only if $AB \cdot CD \cdot EF = BC \cdot DE \cdot FA$.

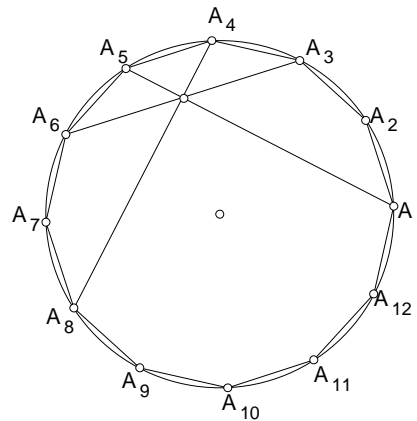
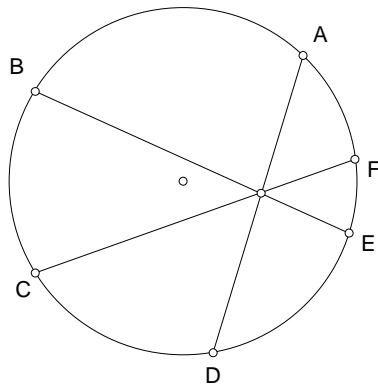

- Let $A_1A_2 \dots A_{12}$ be a regular 12-gon. Show that the diagonals A_1A_5, A_3A_6 and A_4A_8 are concurrent.
- Inside a given circle C is a chain of six circles $C_i, i = 1, 2, 3, 4, 5, 6$,

such that each C_i touches C_{i-1} and C_{i+1} externally. (Remark: $C_7 = C_1$). Suppose each C_i also touches C internally at A_i , $i = 1, 2, 3, 4, 5, 6$. Show that A_1A_4 , A_2A_5 and A_3A_6 are concurrent.⁷

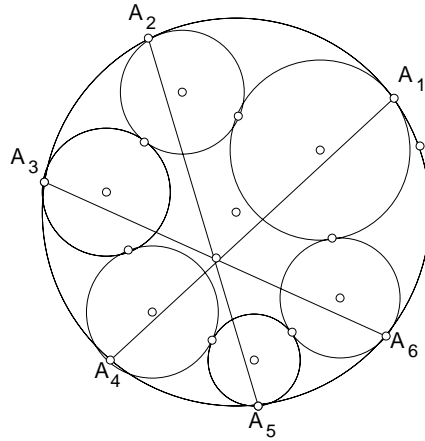

⁷Rabinowitz, The seven circle theorem, Pi Mu Epsilon Journal, vol 8, no. 7 (1987) pp.441 – 449. The statement is still valid if each of the circles C_i , $i = 1, 2, 3, 4, 5, 6$, is outside the circle C .

Chapter 10

Quadrilaterals

10.1 Area formula

Consider a quadrilateral $ABCD$ with sides

$$AB = a, \quad BC = b, \quad CD = c, \quad DA = d,$$

angles

$$\angle DAB = \alpha, \quad \angle ABC = \beta, \quad \angle BCD = \gamma, \quad \angle CDA = \delta,$$

and diagonals

$$AC = x, \quad BD = y.$$

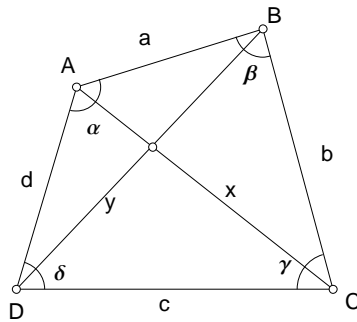

Applying the cosine formula to triangles ABC and ADC , we have

$$x^2 = a^2 + b^2 - 2ab \cos \beta,$$

$$x^2 = c^2 + d^2 - 2cd \cos \delta.$$

Eliminating x , we have

$$a^2 + b^2 - c^2 - d^2 = 2ab \cos \beta - 2cd \cos \delta,$$

Denote by S the area of the quadrilateral. Clearly,

$$S = \frac{1}{2}ab \sin \beta + \frac{1}{2}cd \sin \delta.$$

Combining these two equations, we have

$$\begin{aligned} & 16S^2 + (a^2 + b^2 - c^2 - d^2)^2 \\ &= 4(ab \sin \beta + cd \sin \delta)^2 + 4(ab \cos \beta - cd \cos \delta)^2 \\ &= 4(a^2b^2 + c^2d^2) - 8abcd(\cos \beta \cos \delta - \sin \beta \sin \delta) \\ &= 4(a^2b^2 + c^2d^2) - 8abcd \cos(\beta + \delta) \\ &= 4(a^2b^2 + c^2d^2) - 8abcd[2 \cos^2 \frac{\beta + \delta}{2} - 1] \\ &= 4(ab + cd)^2 - 16abcd \cos^2 \frac{\beta + \delta}{2}. \end{aligned}$$

Consequently,

$$\begin{aligned} 16S^2 &= 4(ab + cd)^2 - (a^2 + b^2 - c^2 - d^2)^2 - 16abcd \cos^2 \frac{\beta + \delta}{2} \\ &= [2(ab + cd) + (a^2 + b^2 - c^2 - d^2)][2(ab + cd) - (a^2 + b^2 - c^2 - d^2)] \\ &\quad - 16abcd \cos^2 \frac{\beta + \delta}{2} \\ &= [(a + b)^2 - (c - d)^2][(c + d)^2 - (a - b)^2] - 16abcd \cos^2 \frac{\beta + \delta}{2} \\ &= (a + b + c - d)(a + b - c + d)(c + d + a - b)(c + d - a + b) \\ &\quad - 16abcd \cos^2 \frac{\beta + \delta}{2}. \end{aligned}$$

Writing

$$2s := a + b + c + d,$$

we reorganize this as

$$S^2 = (s - a)(s - b)(s - c)(s - d) - abcd \cos^2 \frac{\beta + \delta}{2}.$$

10.1.1 Cyclic quadrilateral

If the quadrilateral is cyclic, then $\beta + \delta = 180^\circ$, and $\cos \frac{\beta + \delta}{2} = 0$. The area formula becomes

$$S = \sqrt{(s-a)(s-b)(s-c)(s-d)},$$

where $s = \frac{1}{2}(a + b + c + d)$.

Exercise

1. If the lengths of the sides of a quadrilateral are fixed, its area is greatest when the quadrilateral is cyclic.
2. Show that the Heron formula for the area of a triangle is a special case of this formula.

10.2 Ptolemy's Theorem

Suppose the quadrilateral $ABCD$ is cyclic. Then, $\beta + \delta = 180^\circ$, and $\cos \beta = -\cos \delta$. It follows that

$$\frac{a^2 + b^2 - x^2}{2ab} + \frac{c^2 + d^2 - x^2}{2cd} = 0,$$

and

$$x^2 = \frac{(ac + bd)(ad + bc)}{ab + cd}.$$

Similarly, the other diagonal y is given by

$$y^2 = \frac{(ab + cd)(ac + bd)}{(ad + bc)}.$$

From these, we obtain

$$xy = ac + bd.$$

This is Ptolemy's Theorem. We give a synthetic proof of the theorem and its converse.

10.2.1 Ptolemy's Theorem

A convex quadrilateral $ABCD$ is cyclic if and only if

$$AB \cdot CD + AD \cdot BC = AC \cdot BD.$$

Proof. (Necessity) Assume, without loss of generality, that $\angle BAD > \angle ABD$. Choose a point P on the diagonal BD such that $\angle BAP = \angle CAD$. Triangles BAP and CAD are similar, since $\angle ABP = \angle ACD$. It follows that $AB : AC = BP : CD$, and

$$AB \cdot CD = AC \cdot BP.$$

Now, triangles ABC and APD are also similar, since $\angle BAC = \angle BAP + \angle PAC = \angle DAC + \angle PAC = \angle PAD$, and $\angle ACB = \angle ADP$. It follows that $AC : BC = AD : PD$, and

$$BC \cdot AD = AC \cdot PD.$$

Combining the two equations, we have

$$AB \cdot CD + BC \cdot AD = AC(BP + PD) = AC \cdot BD.$$

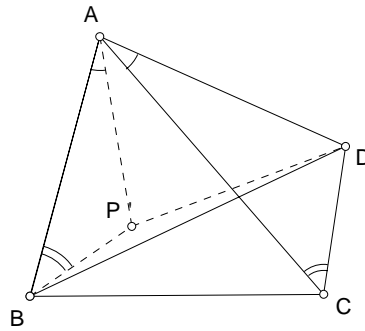
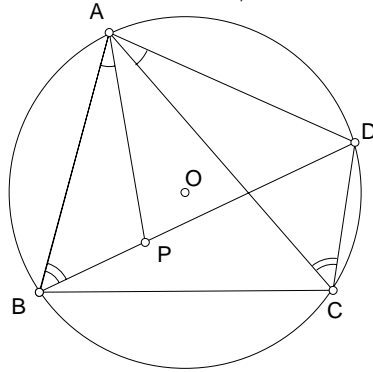

(Sufficiency). Let $ABCD$ be a quadrilateral satisfying (**). Locate a point P' such that $\angle BAP' = \angle CAD$ and $\angle ABP' = \angle ACD$. Then the triangles ABP' and ACD are similar. It follows that

$$AB : AP' : BP' = AC : AD : CD.$$

From this we conclude that

- (i) $AB \cdot CD = AC \cdot BP'$, and

(ii) triangles ABC and $AP'D$ are similar since $\angle BAC = \angle P'AD$ and $AB : AC = AP' : AD$.

Consequently, $AC : BC = AD : P'D$, and

$$AD \cdot BC = AC \cdot P'D.$$

Combining the two equations,

$$AC(BP' + P'D) = AB \cot CD + AD \cdot BC = AC \cdot BD.$$

It follows that $BP' + P'D = BC$, and the point P' lies on diagonal BD . From this, $\angle ABD = \angle ABP' = \angle ACD$, and the points A, B, C, D are concyclic.

Exercise

1. Let P be a point on the minor arc BC of the circumcircle of an equilateral triangle ABC . Show that $AP = BP + CP$.

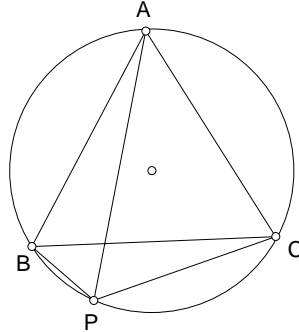

2. P is a point on the incircle of an equilateral triangle ABC . Show that $AP^2 + BP^2 + CP^2$ is constant. ¹

¹If each side of the equilateral triangle has length $2a$, then $AP^2 + BP^2 + CP^2 = 5a^2$.

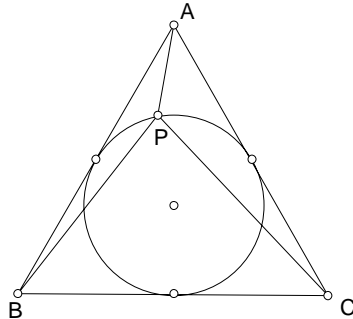

3. Each diagonal of a convex quadrilateral bisects one angle and trisects the opposite angle. Determine the angles of the quadrilateral. ²
4. If three consecutive sides of a CONVEX, cyclic quadrilateral have lengths a , b , c , and the fourth side d is a diameter of the circumcircle, show that d is the real root of the cubic equation

$$x^3 - (a^2 + b^2 + c^2)x - 2abc = 0.$$

5. One side of a cyclic quadrilateral is a diameter, and the other three sides have lengths 3, 4, 5. Find the diameter of the circumcircle.
6. The radius R of the circle containing the quadrilateral is given by

$$R = \frac{(ab + cd)(ac + bd)(ad + bc)}{4S}.$$

10.2.2

If $ABCD$ is cyclic, then

$$\tan \frac{\alpha}{2} = \sqrt{\frac{(s-a)(s-d)}{(s-b)(s-c)}}.$$

Proof. In triangle ABD , we have $AB = a$, $AD = d$, and $BD = y$, where

$$y^2 = \frac{(ab + cd)(ac + bd)}{ad + bc}.$$

²Answer: Either $A = D = 72^\circ$, $B = C = 108^\circ$, or $A = D = \frac{720}{7}^\circ$, $B = C = \frac{540}{7}^\circ$.

By the cosine formula,

$$\cos \alpha = \frac{a^2 + d^2 - y^2}{2ad} = \frac{a^2 - b^2 - c^2 + d^2}{2(ad + bc)}.$$

In an alternative form, this can be written as

$$\begin{aligned} \tan^2 \frac{\alpha}{2} &= \frac{1 - \cos \alpha}{1 + \cos \alpha} = \frac{(b + c)^2 - (a - d)^2}{(a + d)^2 - (b - c)^2} \\ &= \frac{(-a + b + c + d)(a + b + c - d)}{(a - b + c + d)(a + b - c + d)} = \frac{(s - a)(s - d)}{(s - b)(s - c)}. \end{aligned}$$

Exercise

- Let Q denote an arbitrary convex quadrilateral inscribed in a fixed circle, and let $F(Q)$ be the set of inscribed convex quadrilaterals whose sides are parallel to those of Q . Prove that the quadrilaterals in $F(Q)$ of maximum area is the one whose diagonals are perpendicular to one another. ³
- Let a, b, c, d be positive real numbers.
 - Prove that $a + b > |c - d|$ and $c + d > |a - b|$ are necessary and sufficient conditions for there to exist a convex quadrilateral that admits a circumcircle and whose side lengths, in cyclic order, are a, b, c, d .
 - Find the radius of the circumcircle. ⁴
- Determine the maximum area of the quadrilateral with consecutive vertices A, B, C , and D if $\angle A = \alpha$, $BC = b$ and $CD = c$ are given. ⁵

10.2.3 Construction of cyclic quadrilateral of given sides

10.2.4 The anticenter of a cyclic quadrilateral

Consider a cyclic quadrilateral $ABCD$, with circumcenter O . Let X, Y, Z, W be the midpoints of the sides AB, BC, CD, DA respectively. The midpoint of XZ is the centroid G of the quadrilateral. Consider the perpendicular X to the opposite side CD . Denote by O' the intersection of this

³MG1472.952. (E.Grel)

⁴CMJ545.951.S961. (J.Fukuta)

⁵CMJ538.945.S955. (M.S.Klamkin)

perpendicular with the line OG . Since $O'X \parallel ZO$ and G is the midpoint of XA , it is clear that $O'G = GO$.

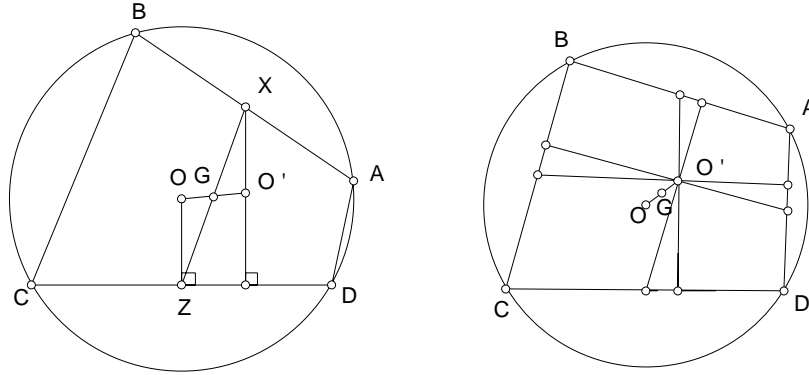

It follows that the perpendiculars from the midpoints of the sides to the opposite sides of a cyclic quadrilateral are concurrent at the point O' , which is the symmetric of the circumcenter in the centroid. This is called the anticenter of the cyclic quadrilateral.

10.2.5

Let P be the midpoint of the diagonal AC . Since $AXPW$ is a parallelogram, $\angle XPW = \angle XAW$. Let X' and W' be the projections of the midpoints X and W on their respective opposite sides. The lines XX' and WW' intersect at O' . Clearly, O', W', C, X'

It follows that the four points P , X , W , and O' are concyclic. Since P , X , W are the midpoints of the sides of triangle ABD , the circle through them is the nine-point circle of triangle ABD . From this, we have

Proposition

The nine-point circles of the four triangles determined by the four vertices of a cyclic quadrilateral pass through the anticenter of the quadrilateral.

10.2.6 Theorem

The incenters of the four triangles determined by the vertices of a cyclic quadrilateral form a rectangle.

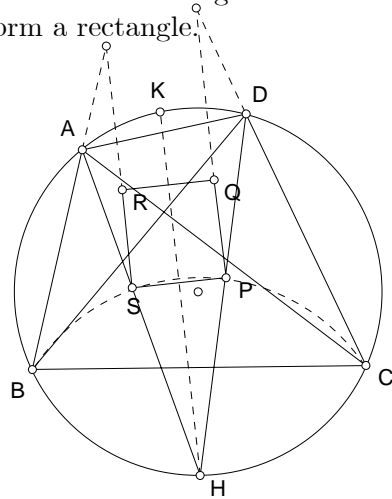

Proof.⁶ The lines AS and DP intersect at the midpoint H of the arc BC on the other side of the circle $ABCD$. Note that P and S are both on the circle $H(B) = H(C)$. If K is the midpoint of the arc AD , then HK , being the bisector of angle AHD , is the perpendicular bisector of PS . For the same reason, it is also the perpendicular bisector of QR . It follows that $PQRS$ is an isosceles trapezium.

The same reasoning also shows that the chord joining the midpoints of the arcs AB and CD is the common perpendicular bisector of PQ and RS . From this, we conclude that $PQRS$ is indeed a rectangle.

⁶Court, p.133.

10.2.7 Corollary

The inradii of these triangles satisfy the relation ⁷

$$r_a + r_c = r_b + r_d.$$

Proof. If AB and CD are parallel, then each is parallel to HK . In this case, $r_a = r_b$ and $r_c = r_d$. More generally,

$$r_a - r_b = PQ \sin \frac{1}{2}(\angle BDC - \angle AHD)$$

and

$$r_d - r_c = SR \sin \frac{1}{2}(\angle BAC - \angle AHD).$$

Since $PQ = SR$ and $\angle BDC = \angle BAC$, it follows that $r_a - r_b = r_d - r_c$, and

$$r_a + r_c = r_b + r_d.$$

Exercise

- Suppose the incircles of triangles $\frac{ABC}{ACD}$ and $\frac{ABD}{BCD}$ touch the diagonal AC at X and BD at Y respectively.

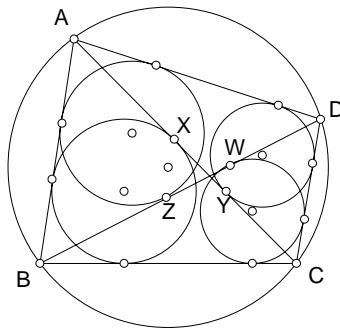

Show that

$$XY = ZW = \frac{1}{2}|a - b + c - d|.$$

⁷The proof given in Fukagawa and Pedoe, Japanese Temple Geometry Problems, p.127, does not cover the case of a bicentric quadrilateral.

10.3 Circumscribable quadrilaterals

A quadrilateral is said to be circumscribable if it has an incircle.

10.3.1 Theorem

A quadrilateral is circumscribable if and only if the two pairs of opposite sides have equal total lengths.

Proof. (Necessity) Clear.

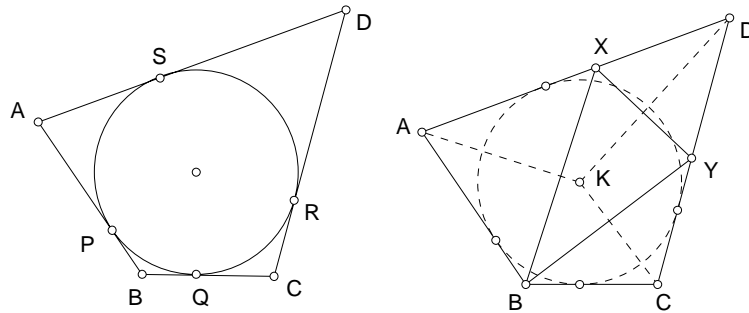

(Sufficiency) Suppose $AB + CD = BC + DA$, and $AB < AD$. Then $BC < CD$, and there are points X on AD such that $AX = AB$ and Y on CD such that $CY = CD$. Then $DX = DY$. Let K be the circumcircle of triangle BXY . AK bisects angle A since the triangles AKX and AKB are congruent. Similarly, CK and DK are bisectors of angles B and C respectively. It follows that K is equidistant from the sides of the quadrilateral. The quadrilateral admits of an incircle with center K .

10.3.2 ⁸

Let $ABCD$ be a circumscribable quadrilateral, X, Y, Z, W the points of contact of the incircle with the sides. The diagonals of the quadrilaterals $ABCD$ and $XYZW$ intersect at the same point.

⁸See Crux 199. This problem has a long history, and usually proved using projective geometry. Charles Trigg remarks that the Nov.-Dec. issue of Math. Magazine, 1962, contains nine proofs of this theorem. The proof here was given by Joseph Konhauser.

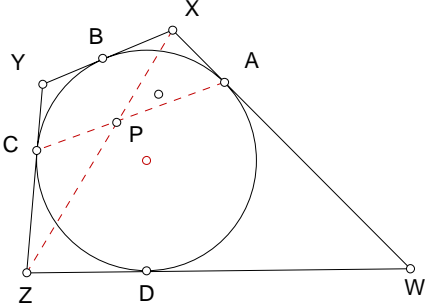
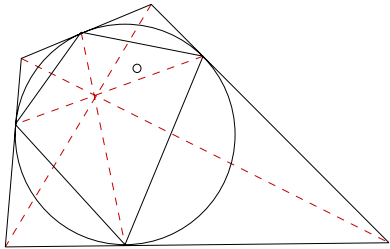

In particular, if the quadrilateral is also cyclic, then

$$S = \sqrt{abcd}.$$

2. If a cyclic quadrilateral with sides a, b, c, d (in order) has area $S = \sqrt{abcd}$, is it necessarily circumscribable? ⁹
3. If the consecutive sides of a **convex**, cyclic and circumscribable quadrilateral have lengths a, b, c, d , and d is a diameter of the circumcircle, show that ¹⁰

$$(a + c)b^2 - 2(a^2 + 4ac + c^2)b + ac(a + c) = 0.$$

4. Find the radius r' of the circle with center I so that there is a quadrilateral whose vertices are on the circumcircle $O(R)$ and whose sides are tangent to $I(r')$.
5. Prove that the line joining the midpoints of the diagonals of a circumscribable quadrilateral passes through the incenter of the quadrilateral. ¹¹

10.4 Orthodiagonal quadrilateral

10.4.1

A quadrilateral is **orthodiagonal** if its diagonals are perpendicular to each other.

10.4.2

A quadrilateral is orthodiagonal if and only if the sum of squares on two opposite sides is equal to the sum of squares on the remaining two opposite sides.

⁹No, when the quadrilateral is a rectangle with unequal sides. Consider the following three statements for a quadrilateral.

- (a) The quadrilateral is cyclic.
- (b) The quadrilateral is circumscribable.
- (c) The area of the quadrilateral is $S = \sqrt{abcd}$.

Apart from the exception noted above, any two of these together implies the third. (Crux 777).

¹⁰Is it possible to find integers a and c so that b is also an integer?

¹¹PME417.78S.S79S.(C.W.Dodge)

Proof. Let K be the intersection of the diagonals, and $\angle AKB = \theta$. By the cosine formula,

$$\begin{aligned} AB^2 &= AK^2 + BK^2 - 2AK \cdot BK \cdot \cos \theta, \\ CD^2 &= CK^2 + DK^2 - 2CK \cdot DK \cdot \cos \theta; \\ BC^2 &= BK^2 + CK^2 + 2BK \cdot CK \cdot \cos \theta, \\ DA^2 &= DK^2 + AK^2 + 2DK \cdot AK \cdot \cos \theta. \end{aligned}$$

Now,

$$BC^2 + DA^2 - AB^2 - CD^2 = 2 \cos \theta (BK \cdot CK + DK \cdot AK + AK \cdot BK + CK \cdot DK)$$

It is clear that this is zero if and only if $\theta = 90^\circ$.

Exercise

1. Let $ABCD$ be a cyclic quadrilateral with circumcenter O . The quadrilateral is orthodiagonal if and only if the distance from O to each side of the $ABCD$ is half the length of the opposite side.¹²
2. Let $ABCD$ be a cyclic, orthodiagonal quadrilateral, whose diagonals intersect at P . Show that the projections of P on the sides of $ABCD$ form the vertices of a bicentric quadrilateral, and that the circumcircle also passes through the midpoints of the sides of $ABCD$.¹³

10.5 Bicentric quadrilateral

A quadrilateral is bicentric if it has a circumcircle and an incircle.

10.5.1 Theorem

The circumradius R , the inradius r , and the the distance d between the circumcenter and the incenter of a bicentric quadrilateral satisfies the relation

$$\frac{1}{r^2} = \frac{1}{(R+d)^2} + \frac{1}{(R-d)^2}.$$

The proof of this theorem is via the solution of a locus problem.

¹²Klamkin, Crux 1062. Court called this Brahmagupta's Theorem.

¹³Crux 2209; also Crux 1866.

10.5.2 Fuss problem

Given a point P inside a circle $I(r)$, $IP = c$, to find the locus of the intersection of the tangents to the circle at X, Y with $\angle XPY = 90^\circ$.

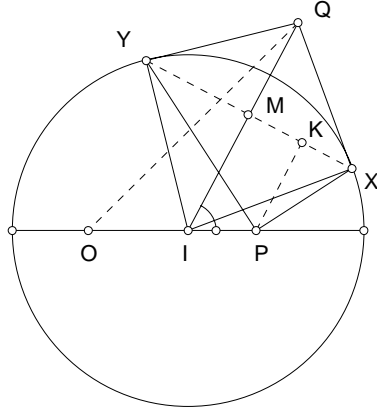

Solution ¹⁴

Let Q be the intersection of the tangents at X and Y , $IQ = x$, $\angle PIQ = \theta$. We first find a relation between x and θ .

Let M be the midpoint of XY . Since IXQ is a right triangle and $XM \perp IQ$, we have $IM \cdot IQ = IX^2$, and

$$IM = \frac{r^2}{x}.$$

Note that $MK = c \sin \theta$, and $PK = IM - c \cos \theta = \frac{r^2}{x} - c \cos \theta$.

Since PK is perpendicular to the hypotenuse XY of the right triangle PXY ,

$$PK^2 = XK \cdot YK = r^2 - IK^2 = r^2 - IM^2 - MK^2.$$

From this, we obtain

$$\left(\frac{r^2}{x} - c \cos \theta\right)^2 = r^2 - \frac{r^4}{x^2} - c^2 \sin^2 \theta,$$

¹⁴See §39 of Heinrich Dörrie, 100 Great Problems of Elementary Mathematics, Dover, 1965.

and, after rearrangement,

$$x^2 + 2x \cdot \frac{cr^2}{r^2 - c^2} \cdot \cos \theta = \frac{2r^4}{r^2 - c^2}.$$

Now, for any point Z on the left hand side with $IZ = d$, we have

$$ZQ^2 = d^2 + x^2 + 2xd \cos \theta.$$

Fuss observed that this becomes constant by choosing

$$d = \frac{cr^2}{r^2 - c^2}.$$

More precisely, if Z is the point O such that OI is given by this expression, then OQ depends only on c and r :

$$OQ^2 = \frac{c^2 r^4}{(r^2 - c^2)^2} + \frac{2r^4(r^2 - c^2)}{(r^2 - c^2)^2} = \frac{r^4(2r^2 - c^2)}{(r^2 - c^2)^2}$$

This means that Q always lies on the circle, center O , radius R given by

$$R^2 = \frac{r^4(2r^2 - c^2)}{(r^2 - c^2)^2}.$$

Proof of Theorem

By eliminating c , we obtain a relation connecting R , r and d . It is easy to see that

$$R^2 = \frac{2r^4(r^2 - c^2) + c^2 r^4}{(r^2 - c^2)^2} = \frac{2r^4}{r^2 - c^2} + d^2,$$

from which

$$R^2 - d^2 = \frac{2r^4}{r^2 - c^2}.$$

On the other hand,

$$R^2 + d^2 = \frac{r^4(2r^2 - c^2)}{(r^2 - c^2)^2} + \frac{c^2 r^4}{(r^2 - c^2)^2} = \frac{2r^6}{(r^2 - c^2)^2}.$$

From these, we eliminate c and obtain

$$\frac{1}{r^2} = \frac{2(R^2 + d^2)}{(R^2 - d^2)^2} = \frac{1}{(R + d)^2} + \frac{1}{(R - d)^2},$$

relating the circumradius, the inradius, and the distance between the two centers of a bicentric quadrilateral.

10.5.3 Construction problem

Given a point I inside a circle $O(R)$, to construct a circle $I(r)$ and a bicentric quadrilateral with circumcircle (O) and incircle (I) .

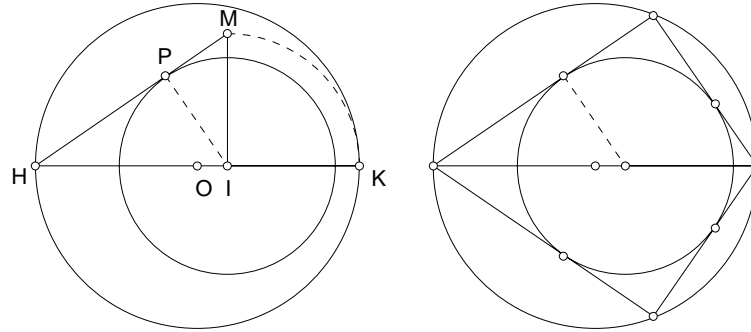

Construction

If I and O coincide, the bicentric quadrilaterals are all squares, $r = \frac{R}{\sqrt{2}}$. We shall assume I and O distinct.

- (1) Let HK be the diameter through I , $IK < IH$. Choose a point M such that IM is perpendicular to IK , and $IK = IM$.
 - (2) Join H, M and construct the projection P of I on HM .
- The circle $I(P)$ is the required incircle.

10.5.4 Lemma

Let Q be a cyclic quadrilateral. The quadrilateral bounded by the tangents to circumcircle at the vertices is cyclic if and only if Q is orthodiagonal.

Proof. Given a cyclic quadrilateral $XYZW$, let $ABCD$ be the quadrilateral bounded by the tangents to the circumcircle at X, Y, Z, W . Since $(\alpha + \gamma) + 2(\theta + \phi) = 360^\circ$, it is clear that $ABCD$ is cyclic if and only if the diagonals XZ and YW are perpendicular.

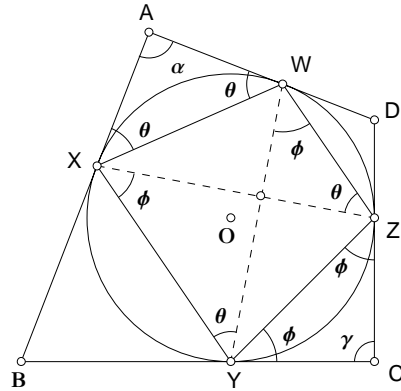

10.5.5 Proposition

(a) Let $ABCD$ be a cyclic, orthodiagonal quadrilateral. The quadrilateral $XYZW$ bounded by the tangents to the circumcircle at the vertices is bi-centric.

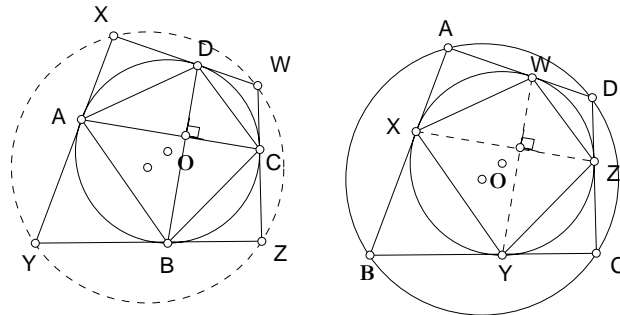

(b) Let $ABCD$ be a bicentric quadrilateral. The quadrilateral $XYZW$ formed by the points of contact with the incircle is orthodiagonal (and circumscribable). Furthermore, the diagonals of $XYZW$ intersect at a point on the line joining the circumcenter and the incenter of $ABCD$.

Exercise

1. The diagonals of a cyclic quadrilateral are perpendicular and intersect at P . The projections of P on the sides form a bicentric quadrilateral,

the circumcircle of which passes through the midpoints of the sides.
¹⁵

2. Characterize quadrilaterals which are simultaneously cyclic, circumscribable, and orthodiagonal. ¹⁶
3. The diagonals of a bicentric quadrilateral intersect at P . Let HK be the diameter of the circumcircle perpendicular to the diagonal AC (so that B and H are on the same side of AC). If HK intersects AC at M , show that $BP : PD = HM : MK$. ¹⁷

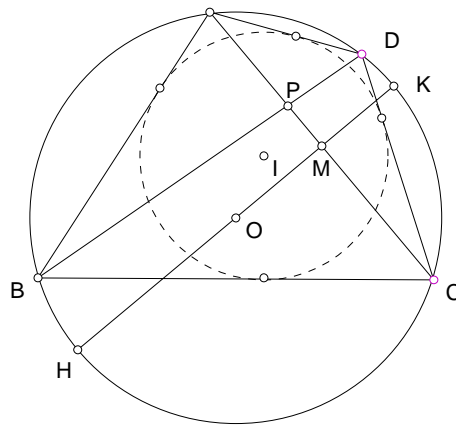

4. Given triangle ABC , construct a point D so that the convex quadrilateral $ABCD$ is bicentric. ¹⁸
5. For a bicentric quadrilateral with diagonals p, q , circumradius R and inradius r , ¹⁹

$$\frac{pq}{4r^2} - \frac{4R^2}{pq} = 1.$$

¹⁵Crux 2209.

¹⁶In cyclic order, the sides are of the form a, a, b, b . (CMJ 304.853; CMJ374.882.S895).

¹⁷D.J.Smeenk, Crux 2027.

¹⁸Let M be the midpoint of AC . Extend BO to N such that $ON = OM$. Construct the circle with diameter BN to intersect AC . The one closer to the shorter side of AB and BC is P . Extend BP to intersect the circumcircle of ABC at D .

¹⁹Crux 1376; also Crux 1203.

10.5.6

The circumcenter, the incenter, and the intersection of the diagonals of a bicentric quadrilateral are concurrent.

10.6

Consider a convex quadrilateral $ABCD$ whose diagonals AC and BD intersect at K . Let A', B', C', D' be the projections of K on the sides AB, BC, CD, DA respectively.

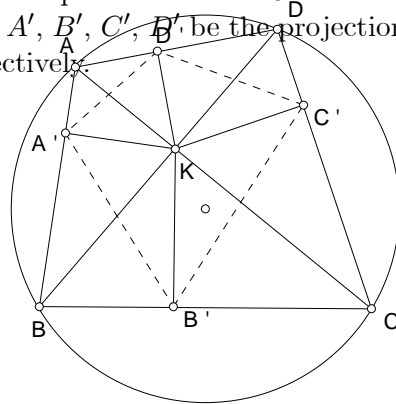

10.6.1 Theorem ²⁰

The quadrilateral $ABCD$ has a circumcircle if and only if $A'B'C'D'$ has an incircle.

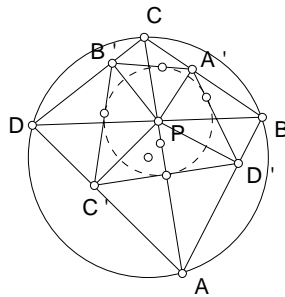

We prove this in two separate propositions.

²⁰Crux 2149, Romero Márquez.

Proposition A.

Let $ABCD$ be a cyclic quadrilateral, whose diagonals intersect at K . The projections of K on the sides of $ABCD$ form the vertices of a circumscribable quadrilateral.

Proof. Note that the quadrilaterals $KA'AB'$, $KB'BC'$, $KC'CD'$, and $KD'DA'$ are all cyclic. Suppose $ABCD$ is cyclic. Then

$$\angle KA'D' = \angle KAD' = \angle CAD = \angle CBD = \angle B'BK = \angle B'A'K.$$

This means K lies on the bisector of angle $D'A'B'$. The same reasoning shows that K also lies on the bisectors of each of the angles B' , C' , D' . From this, $A'B'C'D'$ has an incircle with center K .

Proposition B.

Let $ABCD$ be a circumscribable quadrilateral, with incenter O . The perpendiculars to OA at A , OB at B , OC at C , and OD at D bound a cyclic quadrilateral whose diagonals intersect at O .

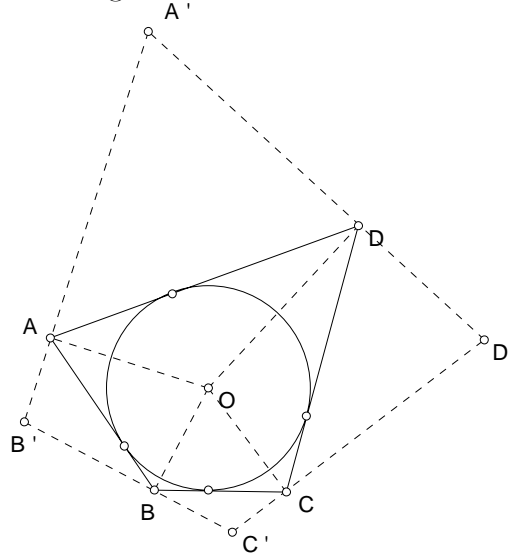

Proof. The quadrilaterals $OAB'B$, $OBC'C$, $OCD'D$, and $ODA'A$ are all cyclic. Note that

$$\angle DOD' = \angle DCD' = \angle BCC'$$

since $OC \perp C'D'$. Similarly, $\angle AOB' = \angle CBC'$. It follows that

$$\angle DOD' + \angle AOD + \angle AOB = \angle$$

10.6.2

Squares are erected outwardly on the sides of a quadrilateral.

The centers of these squares form a quadrilateral whose diagonals are equal and perpendicular to each other.²¹

10.7 Centroids

The centroid G_0 is the center of

The edge-centroid G_1

The face-centroid G_2 :

10.8

10.8.1

A convex quadrilateral is circumscribed about a circle. Show that there exists a straight line segment with ends on opposite sides dividing both the perimeter and the area into two equal parts. Show that the straight line passes through the center of the incircle. Consider the converse.

²²

10.8.2

Draw a straight line which will bisect both the area and the perimeter of a given convex quadrilateral.²³

10.9

Consider a quadrilateral $ABCD$, and the quadrilateral formed by the various centers of the four triangles formed by three of the vertices.

²¹Crux 1179.

²²AMM3878.38?.S406. (V.Thébault). See editorial comment on 837.p486.

²³E992.51?.S52?,531.(K.Tan)

10.9.1

- (a) If Q is cyclic, then $Q_{(O)}$ is circumscribable.
 (b) If Q is circumscribable, then $Q_{(O)}$ is cyclic. ²⁴
 (c) If Q is cyclic, then $Q_{(I)}$ is a rectangle.
 (d) If Q is cyclic, then the nine-point circles of BCD , CDA , DAB , ABC have a point in common. ²⁵.

Exercise

1. Prove that the four triangles of the complete quadrangle formed by the circumcenters of the four triangles of any complete quadrilateral are similar to those triangles. ²⁶
2. Let P be a quadrilateral inscribed in a circle (O) and let Q be the quadrilateral formed by the centers of the four circles internally touching (O) and each of the two diagonals of P . Then the incenters of the four triangles having for sides the sides and diagonals of P form a rectangle inscribed in Q . ²⁷

10.10**10.10.1**

The diagonals of a quadrilateral $ABCD$ intersect at P . The orthocenters of the triangle PAB , PBC , PCD , PDA form a parallelogram that is similar to the figure formed by the centroids of these triangles. What is “centroids” is replaced by circumcenters? ²⁸

²⁴E1055.532.S538.(V.Thébault)

²⁵Crux 2276

²⁶E619.444.S451. (W.B.Clarke)

²⁷Thébault, AMM 3887.38.S837. See editorial comment on 837.p486.

²⁸Crux 1820.

10.11 Quadrilateral formed by the projections of the intersection of diagonals

10.11.1

The diagonals of a convex quadrilateral $ABCD$ intersect at K . P, Q, R, S are the projections of K on the sides $AB, BC, CD,$ and DA . Prove that $ABCD$ is cyclic if $PQRS$ is circumscribable. ²⁹

10.11.2

The diagonals of a convex quadrilateral $ABCD$ intersect at K . P, Q, R, S are the projections of K on the sides $AB, BC, CD,$ and DA . Prove that if $KP = KR$ and $KQ = KS$, then $ABCD$ is a parallelogram. ³⁰

10.12 The quadrilateral $Q'_{(\text{center})}$

10.12.1

If $Q'(I)$ is cyclic, then Q is circumscribable. ³¹

10.12.2 The Newton line of a quadrilateral

L and M are the midpoints of the diagonals AC and BD of a quadrilateral $ABCD$. The lines AB, CD intersect at E , and the lines AD, BC intersect at F . Let N be the midpoint of EF .

Then the points L, M, N are collinear.

Proof. Let P, Q, R be the midpoints of the segments AE, AD, DE respectively. Then L, M, N are on the lines PQ, QR, RP respectively. Apply the Menelaus theorem to the transversal BCF of $\triangle EAD$.

²⁹Crux 2149.

³⁰W.Pompe, Crux 2257.

³¹Seimiya, Crux 2338.

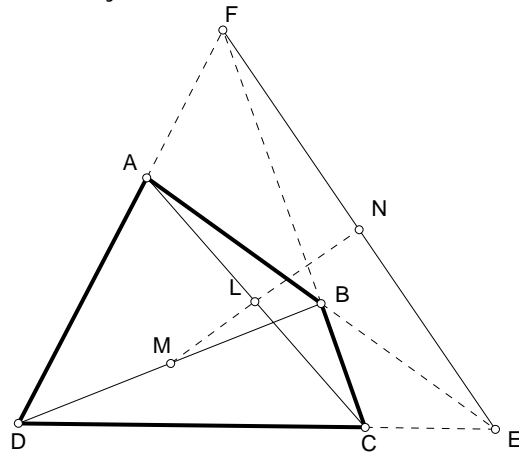

Exercise

1. ³² Suppose $ABCD$ is a plane quadrilateral with no two sides parallel. Let AB and CD intersect at E and AD, BC intersect at F . If M, N, P are the midpoints of AC, BD, EF respectively, and $AE = a \cdot AB, AF = b \cdot AD$, where a and b are nonzero real numbers, prove that $MP = ab \cdot MN$.
2. ³³ The Gauss-Newton line of the complete quadrilateral formed by the four Feuerbach tangents of a triangle is the Euler line of the triangle.

³² AMM E3299.8810.

³³ AMM 4549.537.S549. (R.Obláth).